

LATITUDE: 41°21'52" LONGITUDE -81°07'50"

LOCATION MAP

THE ASPHALT RESURFACING OF SECTION A-B OF HOOVER ROAD

C:\Users\jgibson\OneDrive\Documents\2026\RS-0209-AB-2026\HooR\Road\000\BSP\001\TOWNSHIP\Design\2026\RS-0209-AB-2026\HooR\Road\000\BSP\001\TOWNSHIP\Design\2026\RS-0209-AB-2026-EPIC.dwg

12/18/2025 10:14:29

DESIGNER	HEL
REVIEWER	HAE 04/20/2026
PROJECT ID	RS-0209-AB-2026
SHEET	TOTAL
P.3	P.14

UTILITIES

THE CONTRACTOR SHALL CONTACT OHIO811 A MINIMUM OF TWO (2) WORKING DAYS PRIOR TO COMMENCING ANY WORK. CALL 8-1-1 OR (800) 362-2764 OR GO TO [HTTPS://OUPS.ORG/](https://oups.org/). THERE ARE NO UNDERGROUND UTILITIES SHOWN ON THIS PLAN. THE NATURE OF THE WORK REQUIRED BY THIS PROJECT WILL NOT AFFECT ANY KNOWN UNDERGROUND UTILITIES THAT EXIST UNDER, OR ADJACENT TO, THE WORK AREA. LISTED BELOW ARE ALL UTILITIES LOCATED WITHIN THE PROJECT CONSTRUCTION LIMITS TOGETHER WITH THEIR RESPECTIVE OWNERS:

ELECTRIC: ILLUMINATING COMPANY 7755 AUBURN ROAD CONCORD, OH 44077 (440) 358-4944	GAS: ENBRIDGE GAS OHIO 320 SPRINGSIDE DR SUITE 320 AKRON, OHIO 44333 (330) 664-2409	GAS: DIVERSIFIED GAS & OIL 1823 OH-14 DEERFIELD, OH 44411 (330) 654-4343	CABLE: CHARTER (SPECTRUM) 7820 DIVISION DRIVE MENTOR, OH 44060 (440) 343-1530
---	---	---	--

TELEPHONE:
AT&T
13630 LORAIN AVE
FLOOR 2
CLEVELAND, OH 44111
(216) 476-6142

LOCAL OFFICIALS

THE CONTRACTOR SHALL NOTIFY THE LOCAL FIRE DEPARTMENT, POLICE AND OTHER APPROPRIATE AGENCIES THAT MAY REQUIRE THE USE OF THE ROAD DURING EMERGENCY SITUATIONS. IF ANY AREA BECOMES INACCESSIBLE AT ANY TIME, THE CONTRACTOR SHALL IMMEDIATELY NOTIFY THE AGENCIES OF THESE LOCATIONS. THE CONTRACTOR SHALL SCHEDULE HIS WORK AND COORDINATE WITH LOCAL SCHOOLS AS LISTED BELOW TO ACCOMMODATE THE PICK-UP AND DELIVERY OF SCHOOL STUDENTS IF APPLICABLE.

GEAUGA COUNTY SHERIFF 12450 MERRITT ROAD CHARDON, OH 44024 (440) 279-2009	STATE HIGHWAY PATROL 530 CENTER STREET CHARDON, OH 44024 (440) 286-6612	GEAUGA TRANSIT 12555 MERRITT ROAD CHARDON, OH 44024 (440) 279-2150
--	--	---

THE METZENBAUM CENTER 8200 CEDAR ROAD CHESTERLAND, OH 44026 (440) 729-9406	BERKSHIRE SCHOOL DISTRICT 14155 CLARIDON TROY ROAD BURTON, OH 44021 (440) 834-2058	TROY TOWNSHIP FIRE DEPT. 14019 NASH ROAD BURTON, OH 44021 (440) 834-1810
---	---	---

USPS - HIRAM 11676 HAYDEN AVENUE HIRAM, OH 44234 (330) 569-7881	USPS - GARRETTSVILLE 10809 NORTH STREET GARRETTSVILLE, OH 44231 (330) 527-2888
--	---

CONTINGENCY QUANTITIES

THE CONTRACTOR SHALL NOT ORDER MATERIALS OR PERFORM WORK FOR ITEMS DESIGNATED BY PLAN NOTE TO BE USED "AS DIRECTED BY THE ENGINEER" UNLESS AUTHORIZED BY THE ENGINEER. THE ACTUAL WORK LOCATIONS AND QUANTITIES USED FOR SUCH ITEMS SHALL BE INCORPORATED INTO THE CONTRACTORS MONTHLY INVOICES.

PRECONSTRUCTION MEETING

A PRE-CONSTRUCTION CONFERENCE WILL BE SCHEDULED BY THE ENGINEER WITH THE CONTRACTOR PRIOR TO THE START OF CONSTRUCTION. THE CONTRACTOR SHALL SUBMIT A DETAILED SCHEDULE OF OPERATIONS FOR APPROVAL 24 HOURS PRIOR TO THE PRE-CONSTRUCTION MEETING. THE CONTRACTOR SHALL NOTIFY THE ENGINEER AT LEAST SEVEN (7) DAYS IN ADVANCE OF THE BEGINNING OF CONSTRUCTION, SO THE ENGINEER MAY SCHEDULE THE INSPECTION.

GENERAL NOTES

DESIGNER HEL
REVIEWER HAE 04/20/2026
PROJECT ID RS-0209-AB-2026
SHEET TOTAL P.5 P.14

SEQUENCE OF CONSTRUCTION

UNLESS APPROVED BY THE ENGINEER, THE CONTRACTOR SHALL PLAN AND PROSECUTE THE WORK IN ACCORDANCE WITH THE SEQUENCE OF CONSTRUCTION:

1. PRE-CONSTRUCTION MEETING
2. TRAFFIC MAINTENANCE INSTALL / MOBILIZATION
3. BASE ASPHALT COURSE
4. BASE ASPHALT DRIVEWAYS
5. SURFACE ASPHALT DRIVEWAYS
6. SURFACE COURSE
7. COMPACTED AGGREGATE BERM
8. MAILBOX ADJUSTMENT
9. SEAL JOINTS
10. PERMANENT PAVEMENT MARKINGS
11. INCIDENTALS / PUNCH LIST

ITEM 202 - PAVEMENT REMOVED CONCRETE (DRIVEWAYS)

THE CONTRACTOR SHALL REMOVE PAVEMENT AT THE FOLLOWING LOCATIONS: 14389, 14675, 14720, AND 14845. A FULL-DEPTH DOUBLE SAW-CUT SHALL BE MADE AT THE REMOVAL LIMITS. CARE SHALL BE TAKEN TO NOT DAMAGE ADJACENT PAVEMENT. THE TRENCH LEFT BY THE REMOVAL OPERATION SHALL BE TEMPORARILY FILLED WITH SUITABLE MATERIAL IN ORDER TO MAINTAIN ACCESS. PAVEMENT REMOVAL LIMITS WILL BE CLEARLY MARKED BY THE ENGINEER.

THE COST TO SAWCUT, REMOVE ASPHALT AND SUBGRADE MATERIALS TO THE PROPER DEPTH, REMOVE WASTE MATERIALS, SUBGRADE COMPACTION, TEMPORARY MATERIALS FOR ACCESS RAMPS AND MAINTENANCE SHALL BE INCLUDED IN THE UNIT PRICE FOR THIS ITEM. INSTALL ACCESS RAMPS AT THE TIME OF THE REMOVAL OF THE ASPHALT.

ITEM 202 - WEARING COURSE REMOVED

BUTT JOINTS, PER ODOT SCD BP-3.1, SHALL BE REQUIRED AT THE LOCATIONS LISTED BELOW. THE EXACT LOCATIONS OF ALL BUTT JOINTS WILL BE MARKED IN THE FIELD BY THE ENGINEER. THE EXISTING PAVEMENT SHALL BE GROUND TRANSVERSELY, USING A SELF-PROPELLED GRINDER AS APPROVED BY THE ENGINEER. THE CONTRACTOR SHALL REMOVE ALL GRINDINGS FROM THE JOB SITE AND THOROUGHLY SWEEP THE ROADWAY BEFORE OPENING IT UP TO TRAFFIC.

HOOVER ROAD AT CLARIDON TROY ROAD	105 SY
HOOVER ROAD AT JUG STREET WEST OF INTERSECTION	75 SY
HOOVER ROAD AT JUG STREET EAST OF INTERSECTION	70 SY
HOOVER ROAD AT MUMFORD ROAD	70 SY

ITEM 253 - PAVEMENT REPAIR

THIS ITEM SHALL INCLUDE ALL LABOR, EQUIPMENT, AND MATERIAL NECESSARY TO REMOVE AND REPLACE THE EXISTING ASPHALT PAVEMENT AND BASE, AS MARKED BY THE ENGINEER. THE ASPHALT PAVEMENT AND BASE IN THE REPAIR AREAS SHALL BE REMOVED BY THE GRINDING OR SAW CUTTING METHODS WITHOUT DISPLACING OR DAMAGING THE REMAINING PAVEMENT. THE EXCAVATED TRENCH SHALL BE COMPACTED UTILIZING APPROVED COMPACTION EQUIPMENT. ALL FACES ADJOINING THE EXISTING PAVEMENT SHALL BE CLEANED AND THOROUGHLY COATED WITH AN APPROVED LIQUID ASPHALT MATERIAL. THE CONTRACTOR SHALL USE ITEM 301 ASPHALT CONCRETE BASE TO REPLACE THE EXCAVATED MATERIAL. THE COST OF THE MATERIAL SHALL BE INCLUDED IN THE UNIT PRICE FOR THIS ITEM. THE WORK ZONE SHALL FOLLOW THE SPECIFICATIONS SET FORTH IN ODOT SCD MT-97.12 WITH CONES TO SEPARATE TRAFFIC FROM THE PAVEMENT REPAIR TRENCHES. CONES SHALL BE PLACED ALONG THE ENTIRE LENGTH OF THE WORK ZONE, NOT AT ISOLATED REPAIR LOCATIONS.

DUE TO UNFORESEEABLE CONDITIONS, REPAIR AREAS WILL BE CLEARLY MARKED BY THE ENGINEER PRIOR TO STARTING. THE ANTICIPATED DEPTH OF PAVEMENT TO BE REMOVED AND REPLACED AT A SPECIFIED DEPTH. ANY ADDITIONAL EXCAVATIONS SHALL BE MADE TO A DEPTH AS DIRECTED BY THE ENGINEER. PAYMENT FOR PAVEMENT REPAIR SHALL BE BY THE CUBIC YARD OF ASPHALT BASE MATERIAL PLACED.

GENERAL NOTES

DESIGNER	HEL
REVIEWER	HAE 04/20/2026
PROJECT ID	RS-0209-AB-2026
SHEET	TOTAL
P.6	P.14

ITEM 301 - ASPHALT CONCRETE BASE, PG64-22, (449)

THE CONTRACTOR SHALL PLACE AN ASPHALT CONCRETE BASE COURSE AS SHOWN ON THE TYPICAL SECTION. A MINIMAL DRIVEWAY APRON FOR VEHICLE ACCESS SHALL BE PAVED WITH THIS COURSE AT THE DIRECTION OF THE ENGINEER. A MINIMUM OF TWO (2) ROLLERS SHALL BE USED WHEN COMPACTING THIS COURSE IN ORDER TO GET PROPER COMPACTION AND PROPER FINISH. A VIBRATORY ROLLER SHALL SERVE AS THE BREAKDOWN ROLLER AND COMPACT WITH VIBRATION USED IN ONLY ONE DIRECTION OF TRAVEL AND A PNEUMATIC ROLLER SHALL BE THE SECOND ROLLER. THE VIBRATORY ROLLER SHALL ALSO SERVE AS THE FINISH ROLLER WITHOUT VIBRATION.

THE CONTRACTOR SHALL PROVIDE A PICK-UP SWEEPER DURING THE PLACEMENT OF THIS COURSE OF ASPHALT. THE SWEEPER SHALL ENSURE SURFACE CLEANLINESS IS ACHIEVED TO THE SATISFACTION OF THE ENGINEER. THE SWEEPER SHALL PERFORM AN INITIAL CLEANING AT THE BEGINNING OF DAILY OPERATIONS AND REMAIN ON SITE THROUGHOUT THE DAY AS NEEDED. THE COST FOR THE PICK-UP SWEEPER SHALL BE INCLUDED IN THE UNIT PRICE FOR THIS ITEM.

ITEM 301 - ASPHALT CONCRETE BASE, PG64-22, (449), (DRIVEWAYS), AS PER PLAN

THE CONTRACTOR SHALL PLACE AN AVERAGE DEPTH OF FOUR AND ONE-HALF INCHES (4.5") AT ALL DRIVEWAYS MARKED BY THE ENGINEER, FOLLOWING THE PLACEMENT OF THE MAINLINE BASE COURSE AND PRIOR TO THE APPLICATION OF THE SURFACE COURSE. ALL ASPHALT AND CONCRETE DRIVES SHALL BE SWEEPED THOROUGHLY AND THEN TACKED WITH ITEM 407 TACK COAT PRIOR TO PAVING THE APRON.

THE PAVING OF THESE AREAS SHALL BE A SEPARATE OPERATION FROM THE MAINLINE PAVING. THE DRIVEWAY APRON PLACEMENT SHALL NOT TAKE PLACE WITHIN A TWENTY-FOUR (24) HOUR PERIOD OF TIME, NOT INCLUDING SUNDAYS, AFTER ALL INTERMEDIATE COURSE IS COMPLETED, UNLESS APPROVED BY THE ENGINEER. THIS ITEM SHALL INCLUDE ALL COSTS FOR PREPARATION AND MATERIAL PLACEMENT INCLUDING BUT NOT LIMITED TO EXCAVATION, CRUSHED LIMESTONE BEDDING, AND ASPHALT PAVING.

DRIVEWAY DETAIL - FULL DEPTH ASPHALT

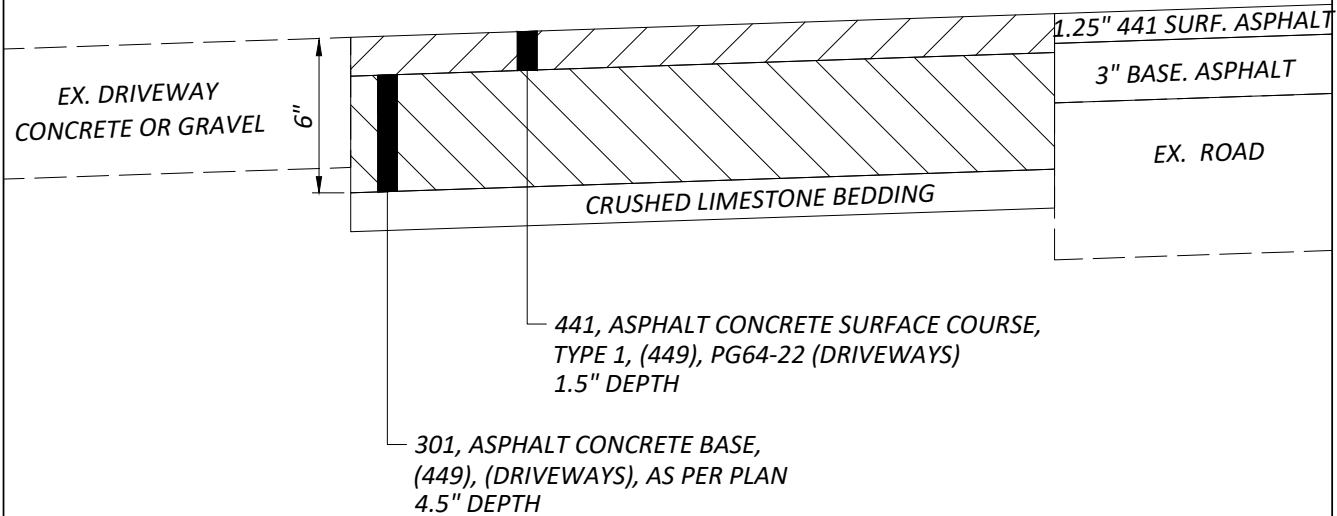

ITEM 407 - NON-TRACKING TACK COAT

NON-TRACKING TACK COAT SHALL BE APPLIED TO THE EXISTING PAVEMENT PRIOR TO THE PLACEMENT OF THE BASE COURSE. THE ENGINEER MAY ADJUST THE APPLICATION RATE OF 0.09 GALLONS PER SQUARE YARD. AN ADDITIONAL QUANTITY OF NON-TRACKING TACK COAT TO BE PLACED ON THE BASE COURSE OF ASPHALT PRIOR TO THE PLACEMENT OF THE SURFACE COURSE IS INCLUDED IN THE TOTAL QUANTITY FOR THIS ITEM. THIS QUANTITY HAS BEEN CALCULATED AT THE APPLICATION RATE OF 0.05 GALLONS PER SQUARE YARD AND SHALL ONLY BE ADJUSTED AT THE DIRECTION OF THE ENGINEER.

GENERAL NOTES

THE ASPHALT RESURFACING OF SECTION A-B OF HOOVER ROAD

C:\Users\jgibson\OneDrive\Documents\2026\RS-0209-AB-2026\Drawings\2026\RS-0209-AB-2026\Notes\RS-0209-AB-2026-11.RVT

DESIGNER	HEL
REVIEWER	HAE 04/20/2026
PROJECT ID	RS-0209-AB-2026
SHEET	TOTAL
P.7	P.14

ITEM 441 - ASPHALT CONCRETE SURFACE COURSE, TYPE 1, (448), PG64-22

THE CONTRACTOR SHALL PLACE A SURFACE COURSE AS SHOWN ON THE TYPICAL SECTION. THE CONTRACTOR SHALL USE THREE (3) ROLLERS TO COMPACT THE SURFACE COURSE INCLUDING TWO (2) TANDEM ROLLERS AND ONE (1) SMALL TANDEM ROLLER. THE SMALL TANDEM ROLLER SHALL BE USED TO COMPACT AREAS WHERE THE LARGE TANDEM ROLLER CANNOT REACH, INCLUDING MAILBOX APPROACHES AND DRIVEWAY TRANSITIONS. VIBRATION SHALL ONLY BE USED AT THE DIRECTION OF THE ENGINEER. DENSITY QUALITY CONTROL TESTING SHALL BE PERFORMED PER 448.02. SEAL ALL TRANSVERSE AND LONGITUDINAL JOINTS PER 401.17.

THE CONTRACTOR SHALL PROVIDE A PICK-UP SWEEPER DURING THE PLACEMENT OF THIS COURSE OF ASPHALT. THE SWEEPER SHALL ENSURE SURFACE CLEANLINESS IS ACHIEVED TO THE SATISFACTION OF THE ENGINEER. THE SWEEPER SHALL PERFORM AN INITIAL CLEANING AT THE BEGINNING OF DAILY OPERATIONS AND REMAIN ON SITE THROUGHOUT THE DAY AS NEEDED. THE COST FOR THE PICK-UP SWEEPER SHALL BE INCLUDED IN THE UNIT PRICE FOR THIS ITEM.

ITEM 441 - ASPHALT CONCRETE SURFACE COURSE, TYPE 1, (449), PG64-22 (DRIVEWAYS)

THE CONTRACTOR SHALL PLACE DRIVEWAY AND INTERSECTION APRONS AT THE LOCATIONS MARKED BY THE ENGINEER. THE PAVING OF THE DRIVEWAYS SHALL BE A SEPARATE OPERATION FROM THE MAINLINE PAVING. THE LENGTHS OF APRONS ARE SUBJECT TO CHANGE AT THE DIRECTION OF THE ENGINEER. THIS OPERATION SHALL BE COMPLETED AFTER THE PLACEMENT OF THE BASE COURSE AND BEFORE THE PLACEMENT OF THE SURFACE COURSE.

ASPHALT SHALL BE PLACED AT A ONE-AND-ONE-HALF INCH (1.5") LIFT. THE APRONS SHALL BE FEATHERED TO MEET EXISTING DRIVEWAY GRADES. ALL ASPHALT DRIVES AND INTERSECTING ROADS SHALL BE SWEEPED THOROUGHLY AND THEN TACKED WITH ITEM 407 NON-TRACKING TACK COAT PRIOR TO PAVING THE APRONS. THE DRIVEWAY APRON PLACEMENT SHALL NOT TAKE PLACE WITHIN A TWENTY-FOUR (24) HOUR PERIOD OF TIME, NOT INCLUDING SUNDAYS, AFTER ALL BASE COURSE IS COMPLETED, UNLESS APPROVED BY THE ENGINEER.

ITEM 617 - COMPACTED AGGREGATE (RAP)

THE CONTRACTOR SHALL PLACE THE STABILIZED SHOULDER BACK UP MATERIAL AS SHOWN IN THE TYPICAL SECTION. THE MATERIAL PLACEMENT SHALL NOT TAKE PLACE WITHIN A TWENTY-FOUR-HOUR (24HR) PERIOD OF TIME, BUT NOT MORE THAN SEVENTY-TWO HOURS (72HRS), AFTER THE PLACEMENT OF THE SURFACE COURSE. THE ROADWAY SHALL BE SWEEPED AFTER THE PLACEMENT OF MATERIAL AND PRIOR TO COMPACTION. THE CONTRACTOR SHALL USE TWO ROLLERS TO COMPACT THE SHOULDER MATERIAL. SEAL ASPHALT JOINTS AT DRIVEWAY AND INTERSECTION APRONS AFTER COMPLETING THIS ITEM.

THE CONTRACTOR SHALL WIDEN THE STABILIZED SHOULDER AT MAILBOX LOCATIONS, AS DIRECTED BY THE ENGINEER, TO PROVIDE FOR SAFE APPROACHES FOR MAIL DELIVERY VEHICLES. THE CONTRACTOR SHALL EXTEND SHOULDER MATERIAL INTO AND ALONG DRIVEWAY APPROACHES TO SERVE AS A SHOULDER TO THE DRIVE APRON. THE DRIVEWAY BACKUP SHALL EXTEND TO THE DRIVE PIPE ALIGNMENT, DITCH LINE, END OF NEW DRIVE APRON OR AS DIRECTED BY THE ENGINEER. FOR EXISTING GRAVEL DRIVEWAYS, THIS ITEM SHALL ALSO SERVE AS THE TRANSITION FROM THE NEW APRON TO THE EXISTING GRAVEL DRIVE.

ITEM 642 - EDGE LINE, 4", TYPE 1

ITEM 642 - CENTER LINE, TYPE 1

THE CONTRACTOR SHALL APPLY PERMANENT PAINT PAVEMENT MARKINGS TO THE NEW ASPHALT SURFACE. THE CONTRACTOR SHALL APPLY PAVEMENT MARKINGS ACCORDING TO THE CENTERLINE LOGS APPROVED BY THE ENGINEER. UNLESS A CENTERLINE LOG IS INCORPORATED INTO THE PROJECT DOCUMENTS, THE CONTRACTOR SHALL RANGE TRACK THE HIGHWAY IN CONFORMANCE WITH THE LEGAL SPEED LIMIT FOR THE PROPER PLACEMENT OF CENTERLINE PAVEMENT MARKINGS. THE RESULTING RANGE TRACKING LOGS SHALL BE PROVIDED TO THE ENGINEER FOR APPROVAL PRIOR TO PLACEMENT OF FINAL MARKINGS THE LANES SHALL BE STRIPED AT A WIDTH OF NINE FEET (9'). EDGE LINES SHALL INCLUDE THE INTERSECTION RADII AND SHALL CONNECT TO THE INTERSECTING ROADWAYS.

GENERAL NOTES

DESIGNER	HEL
REVIEWER	HAE 04/20/2026
PROJECT ID	RS-0209-AB-2026
SHEET	TOTAL
P.8	P.14

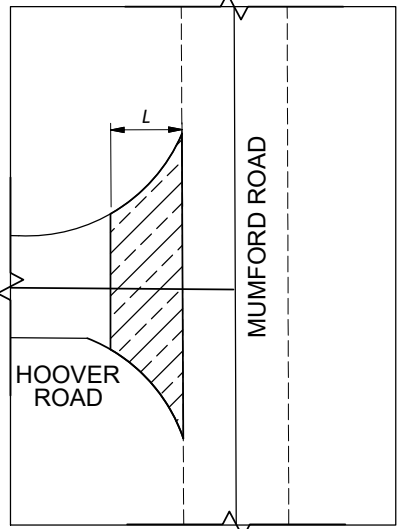
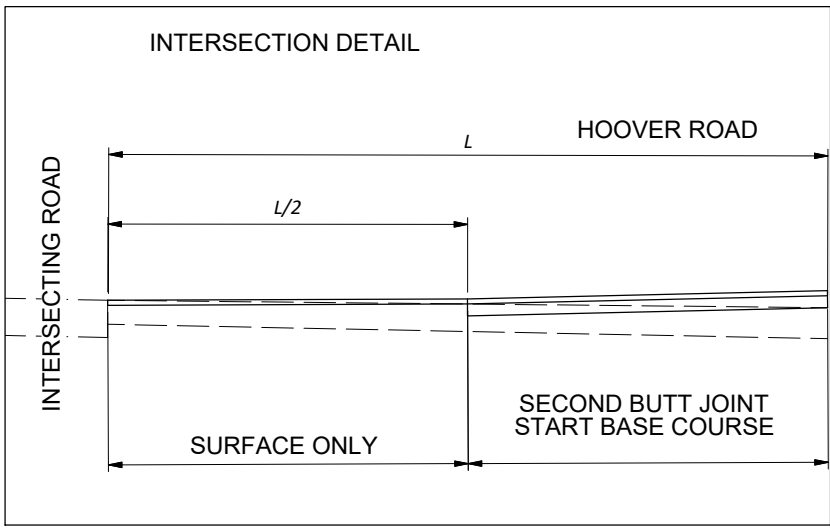
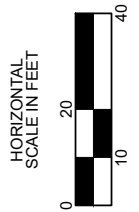
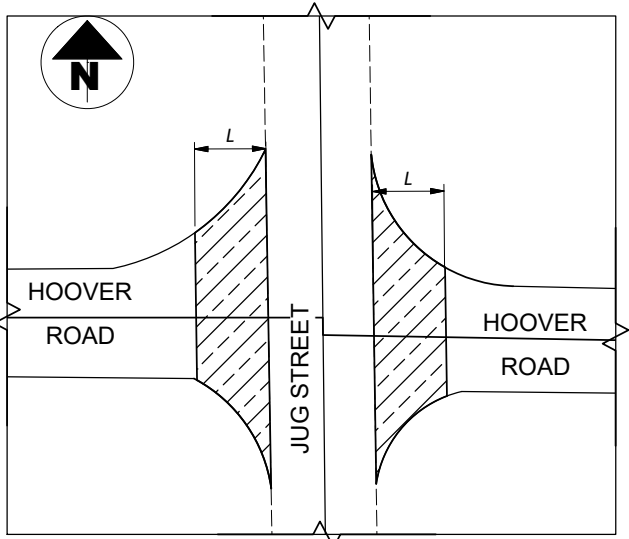
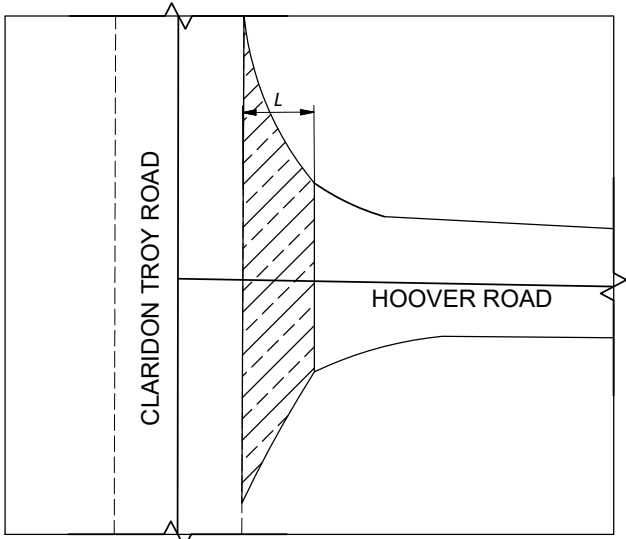

LEGEND

MILL AND SURFACE PAVING ONLY

INTERSECTION DETAILS - HOOVER ROAD

DESCRIPTION	LENGTH L	TOTAL AREA	PROPOSED ITEMS			
			202		441	
			WEARING COURSE REMOVED		ASPHALT CONCRETE SURFACE COURSE, TYPE 1, (449), PG64-22	
	FT	SY	DEPTH	SY	DEPTH	CY
HOOVER ROAD AT CLARIDON TROY ROAD	15	105	1.25"	105	1.25"	3.65
HOOVER ROAD AT JUG STREET (WEST OF INT.)	15	75	1.25"	75	1.25"	2.61
HOOVER ROAD AT JUG STREET (EAST OF INT.)	15	70	1.25"	70	1.25"	2.43
HOOVER ROAD AT MUMFORD ROAD	15	70	1.25"	70	1.25"	2.43
TOTALS CARRIED TO CALCULATIONS SHEETS				320		11.12

DESIGNER HEL
REVIEWER HAE 04/20/2026
PROJECT ID RS-0209-AB-2026
SHEET TOTAL P.14 P.14

REVISIONS	
01-19-2024	
01-21-2022	
01-17-2020	
10-18-2019	
07-18-2014	
04-20-2012	
01-20-2012	
10-19-2007	

SDS ENGINEER
W. Feehan

STATE OF OHIO DEPARTMENT OF
TRANSPORTATION ADMINISTRATOR
Craig Landefeld

ASPHALT PAVING

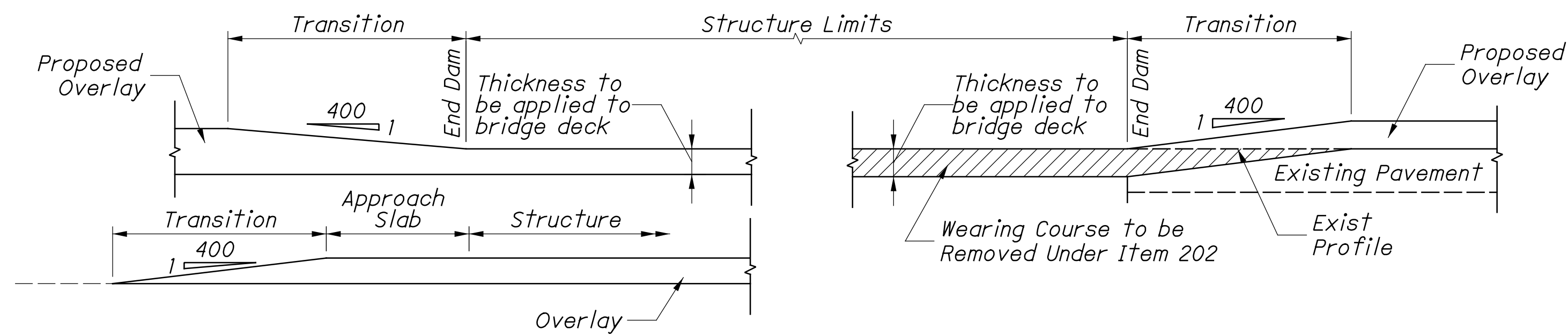

Details assume non-settled approach slabs. Smoothing of the profile for Settlement is required per plan grades or as directed by the Engineer.

TRANSITIONING AT STRUCTURES

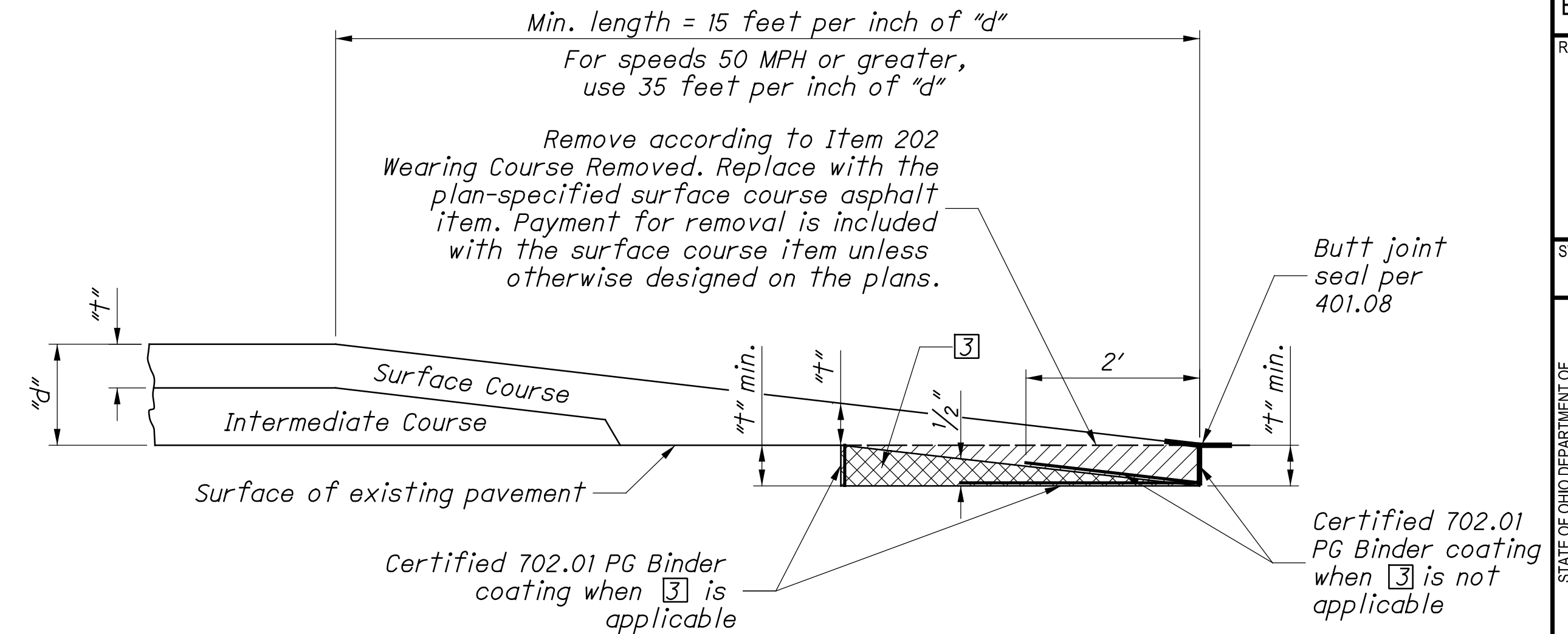

Butt Joint

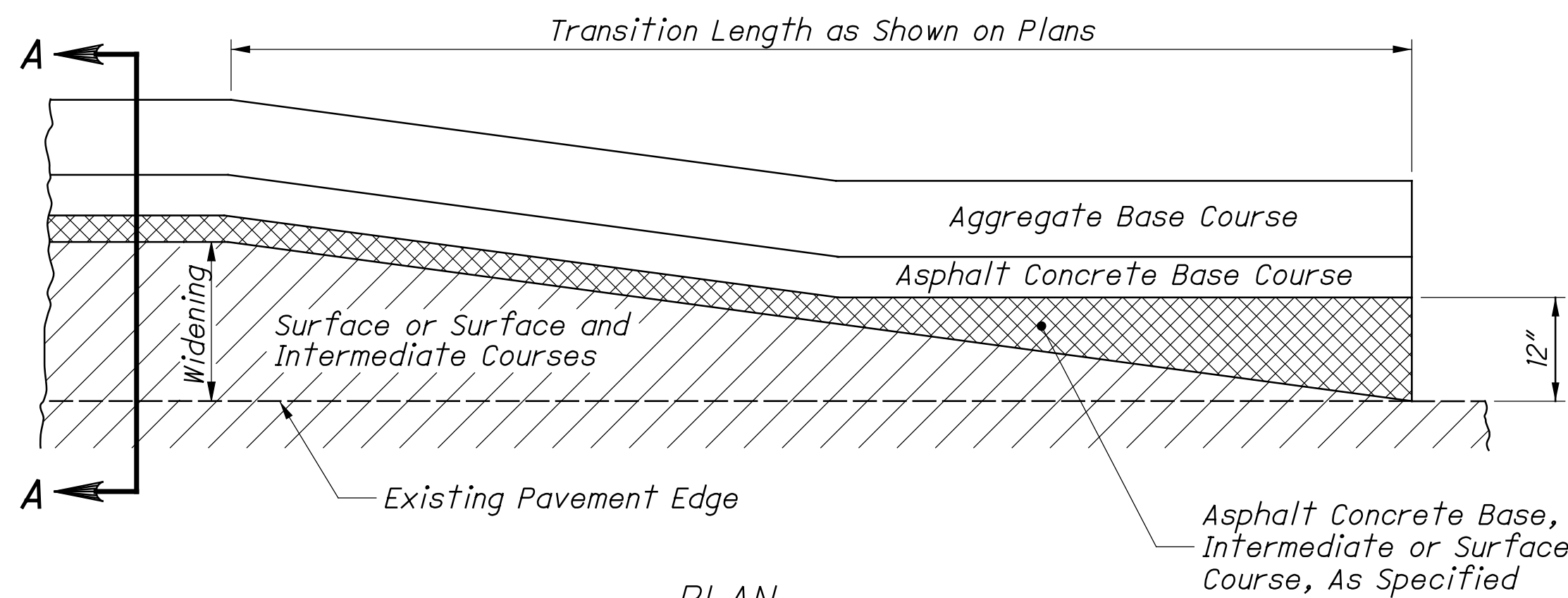

PLAN

MERGING EDGE OF PAVEMENT WIDENING WITH EDGE OF EXISTING PAVEMENT

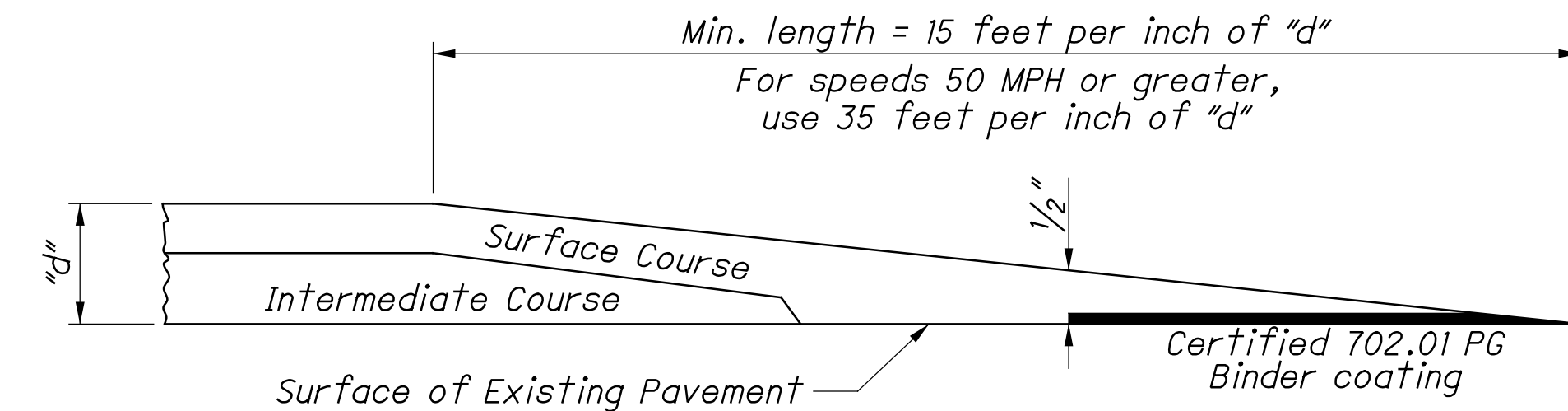

Taper End

NOTE: Butt joint is required unless the taper end is specified in the plans or approved by the Engineer

BUTT JOINTS AND TAPER ENDS

Values for "t" and "d" are obtained from the plans.

LEGEND

- [1] The extended width (X) of a base or subbase lift shall be equal to the depth (Y) of the overlying lift or 6", whichever is greater, or as shown on the plans.
- [2] The extended width shall be equal to the combined thickness of the surface and intermediate courses, or 4", whichever is greater.
- [3] Permissible removal and replacement.
- [4] The bottom of the proposed Asphalt Concrete Base course and Aggregate Base course may not align with the existing pavement or subbase as shown. Ensure the widening subgrade is at or below the existing subgrade to ensure proper drainage.
- [5] Construct the lift shown so that the compacted surface slightly exceeds the elevation of the top of the existing pavement.

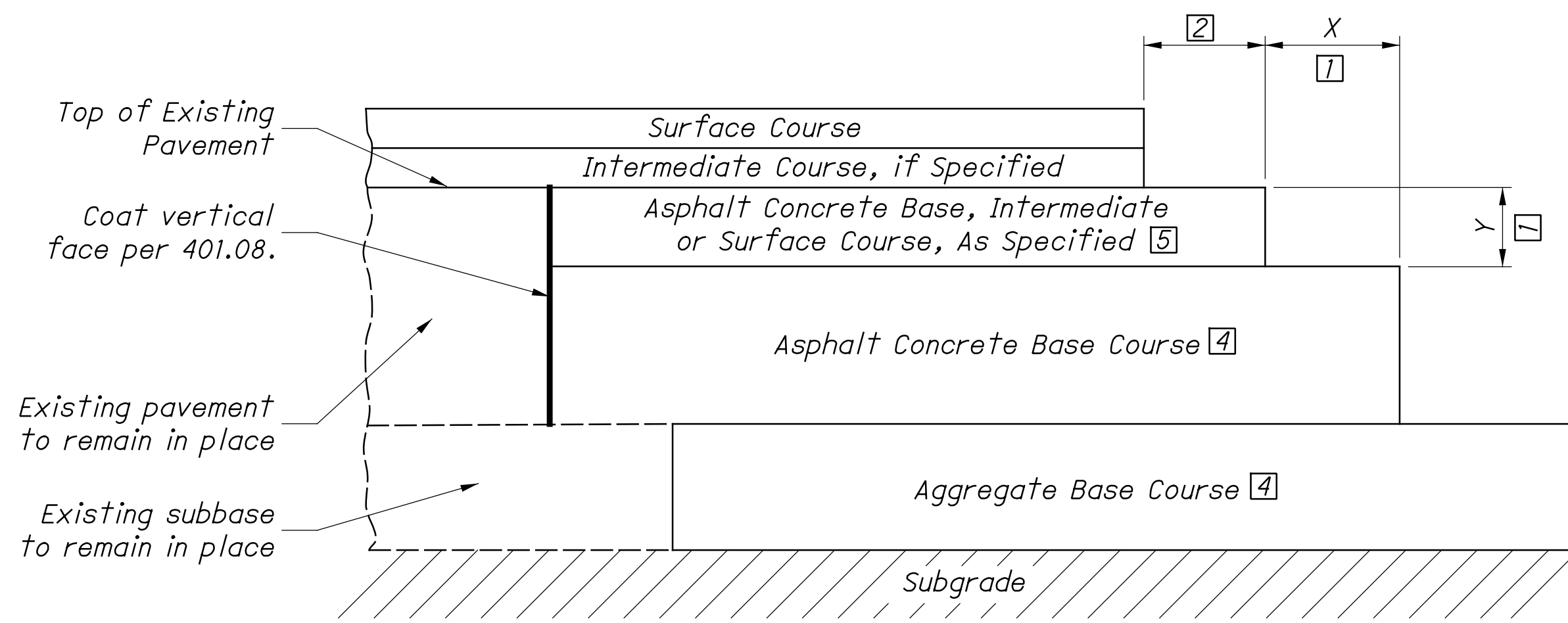

SECTION A-A

COURSE DETAIL FOR WIDENING

Note: Do not use this detail for cold longitudinal joints required by phasing for maintenance of traffic.

DESIGN AGENCY



SCD NUMBER
BP-3.1

SHEET TOTAL
1 2

REVISIONS	
01-19-2024	
01-21-2022	
01-17-2020	
10-18-2019	
07-18-2014	
04-20-2012	
01-20-2012	
10-19-2007	

STDS ENGINEER
W. Feehan

STATE OF OHIO DEPARTMENT OF
TRANSPORTATION ADMINISTRATOR
Craig Landefeld

ASPHALT PAVING

SCD NUMBER BP-3.1
SHEET TOTAL 2 2

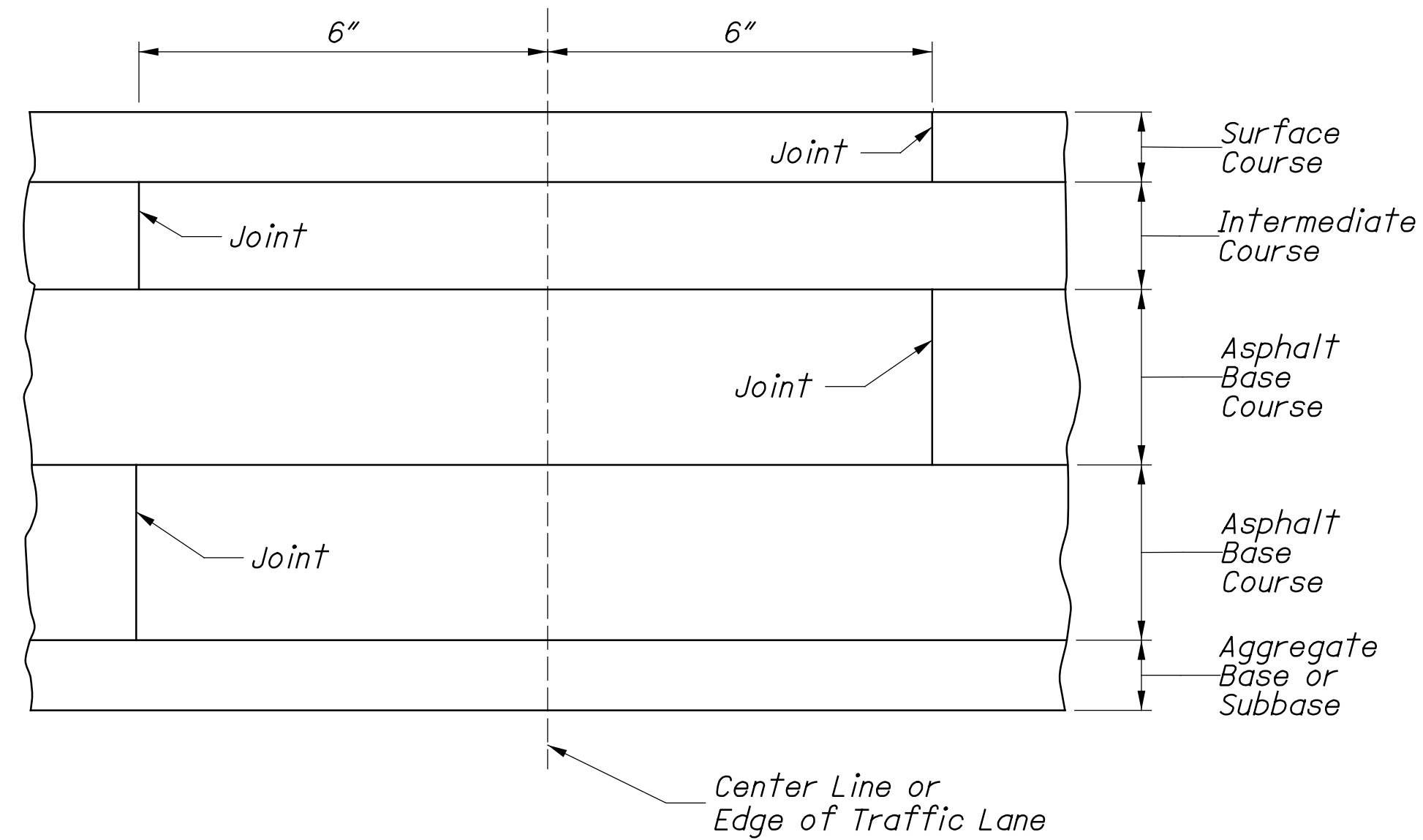

LAPPING LONGITUDINAL JOINTS
(see notes)

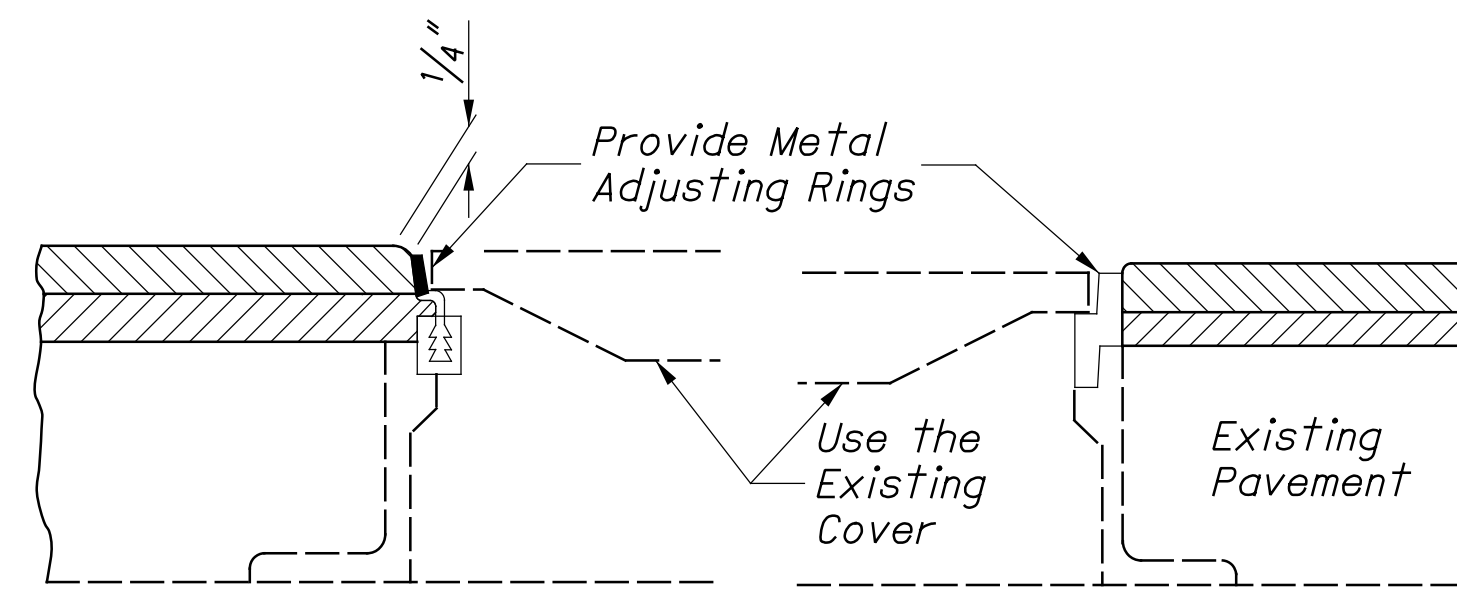

Using Metal Adjusting Rings

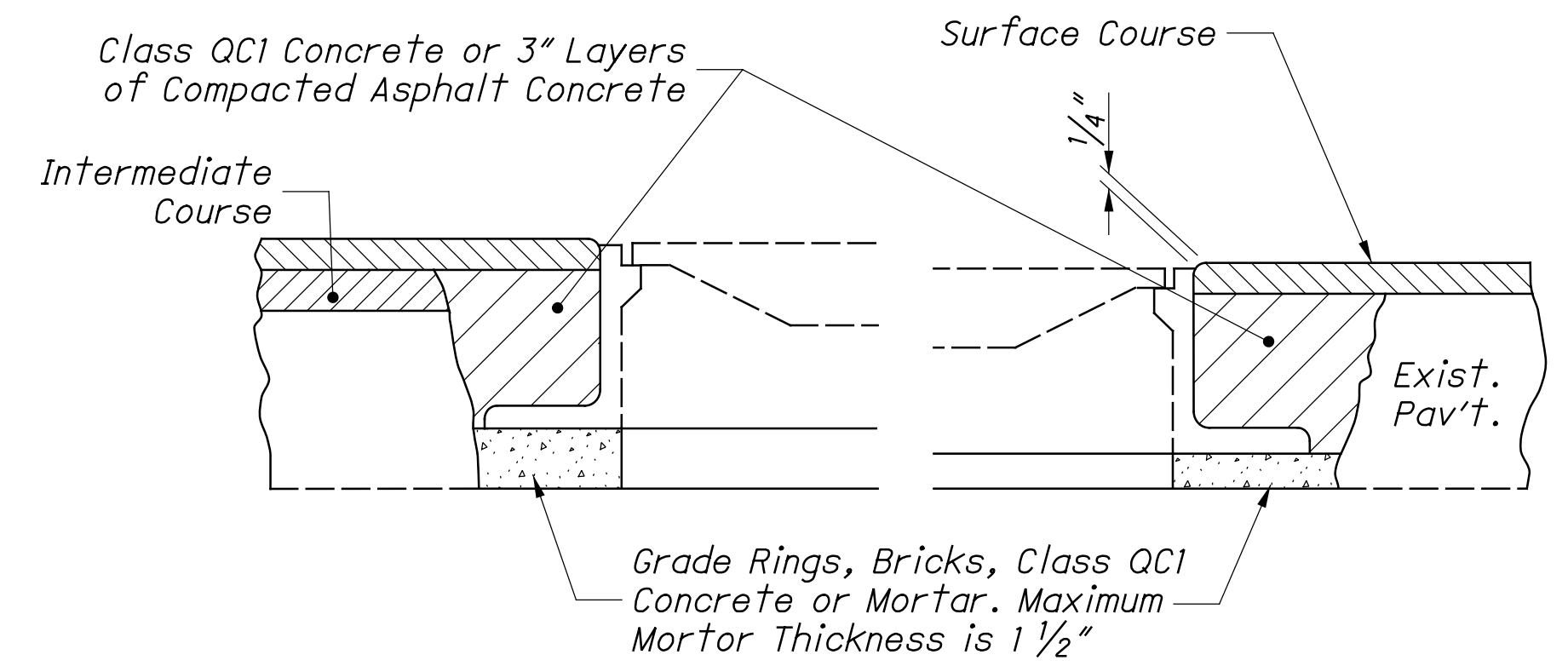

Using Concrete or Mortar

MANHOLES ADJUSTED TO GRADE

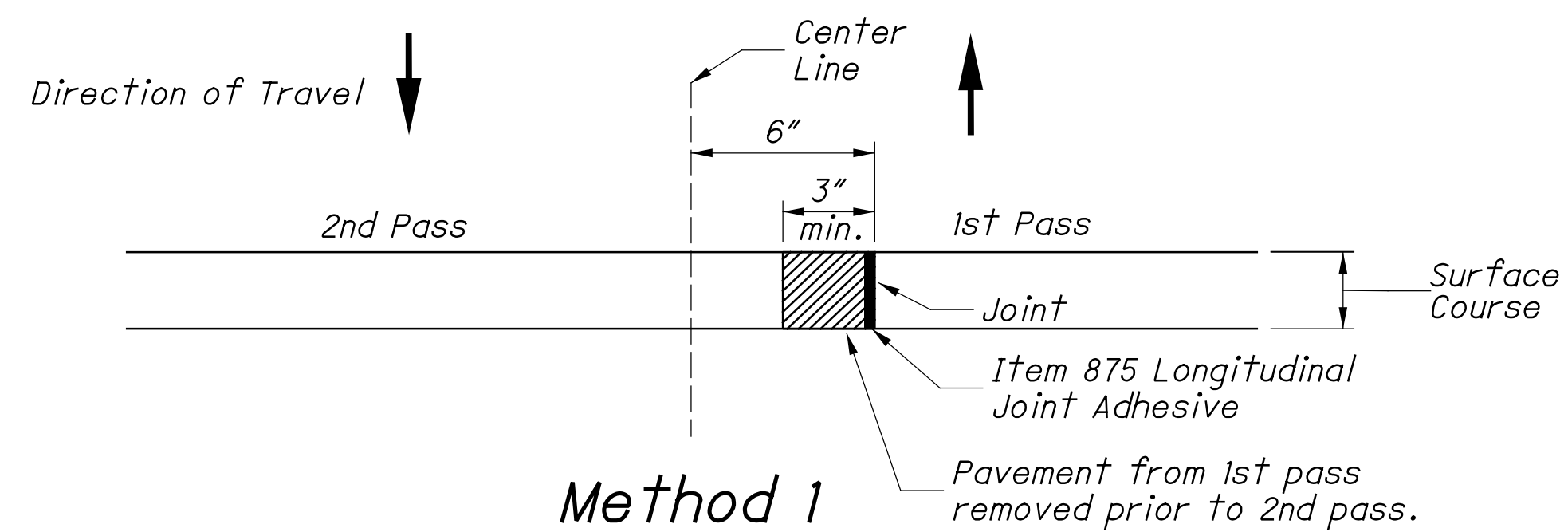

Method 1

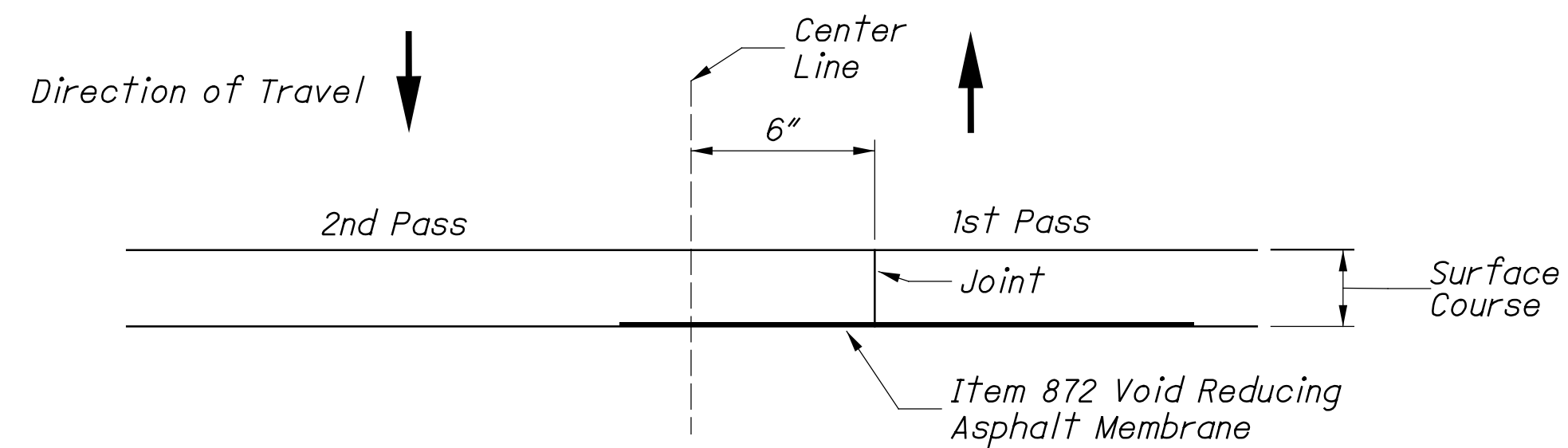

Method 2

LONGITUDINAL JOINT PREPARATION
(if specified)

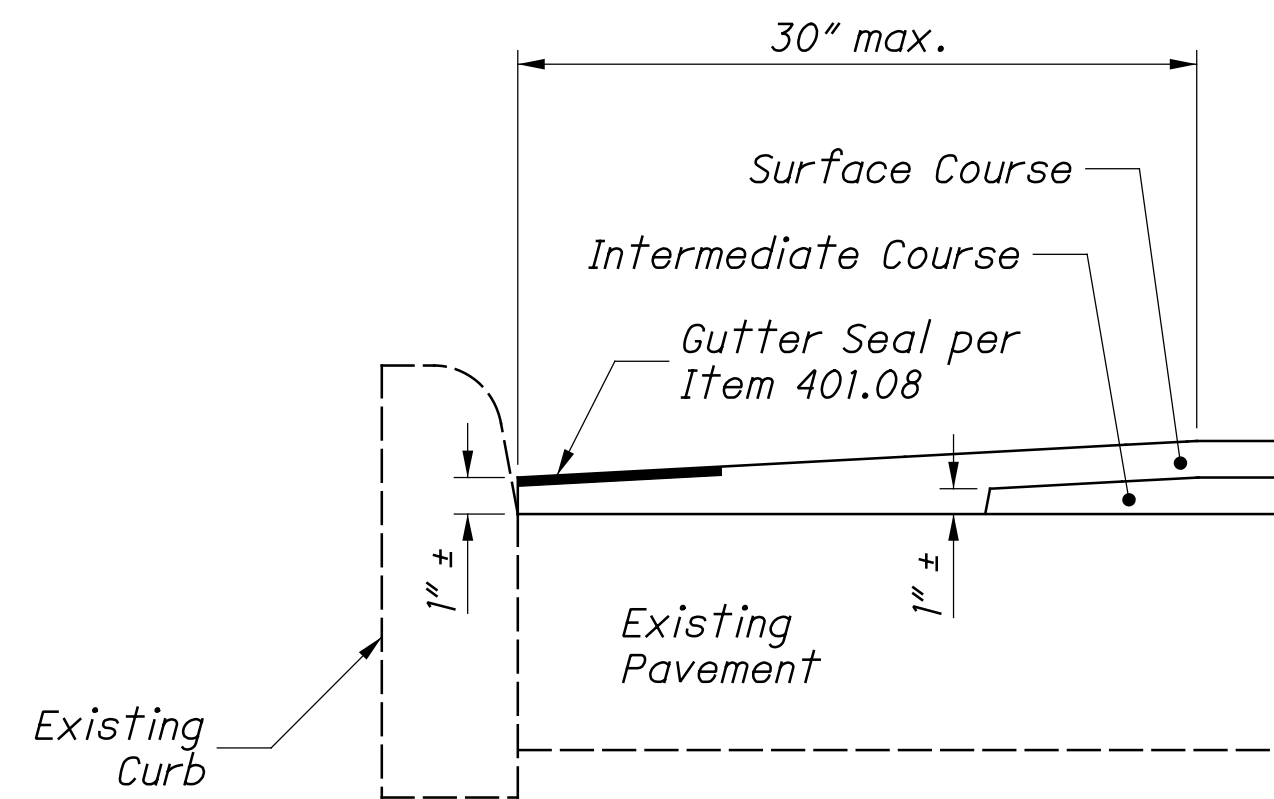

Special care shall be taken during construction to obtain maximum compaction of asphalt concrete in gutters.

GUTTER FINISH

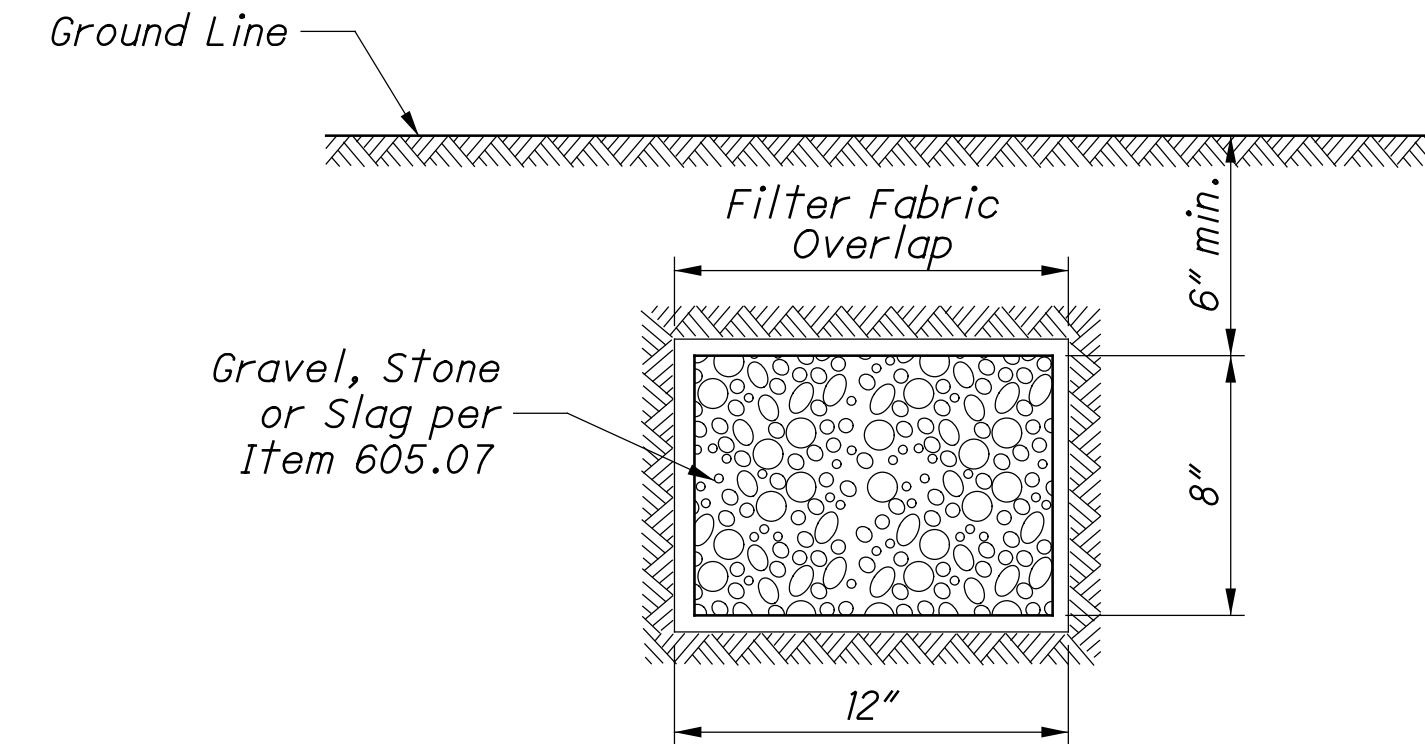

Aggregate drains to be placed where and as directed by Engineer. Provide Filter Fabric when specified as a separate pay item.

AGGREGATE DRAIN

NOTES

GENERAL: Lap all longitudinal joints as shown regardless of the number of courses being placed. Do not construct a longitudinal joint directly above and in line with the longitudinal joint of previously placed material.

METAL ADJUSTING RINGS:

Metal adjusting rings shall:

- (a) Attach securely to the existing frame by welding or mechanical devices;
- (b) Consist either of cast metal having an integral rim and seat, or be fabricated metal with a sturdy connection between the seat and rim; and
- (c) Provide an even seat for the manhole cover.

In addition, the adjusting ring type shall be a design acceptable to the local governmental agency responsible for street and sewer maintenance. Any installation unacceptable to the Engineer shall be replaced by the Contractor at his expense.

PAYMENT: The Department will pay for manholes adjusted to grade using Item 611 Manhole, Catch Basin, or Inlet Adjusted to Grade. The Department will pay for longitudinal joint preparation using Item 874 Longitudinal Joint Preparation.

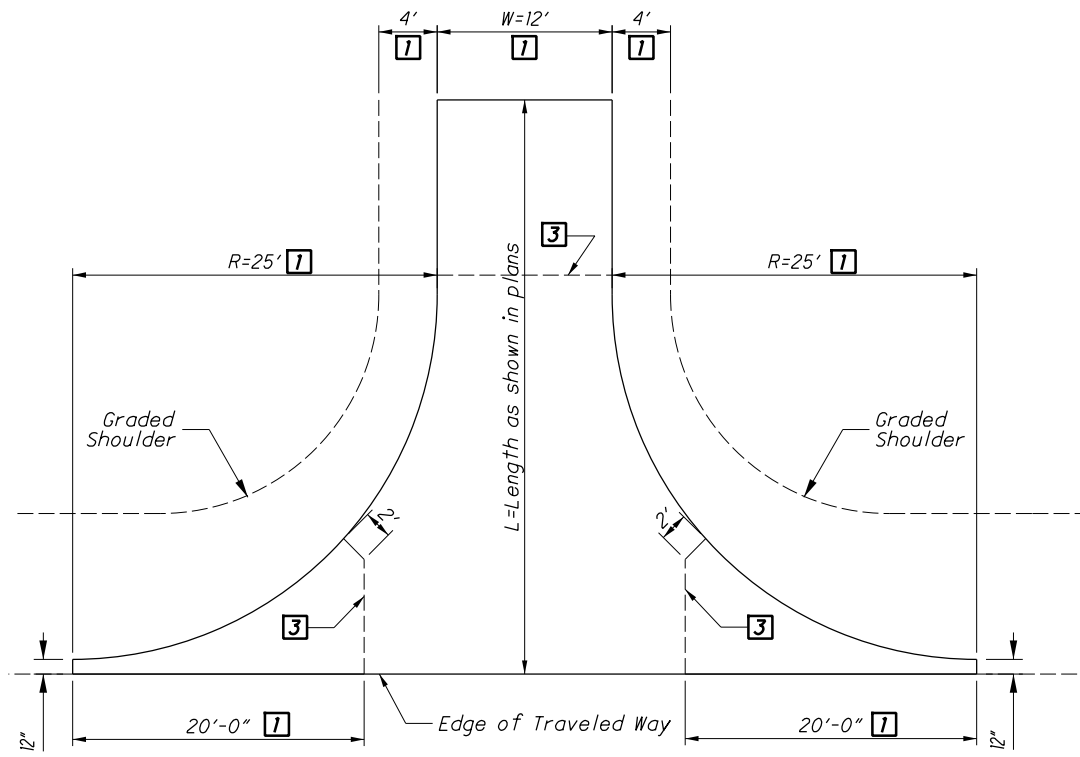

TYPE 1 DRIVEWAY

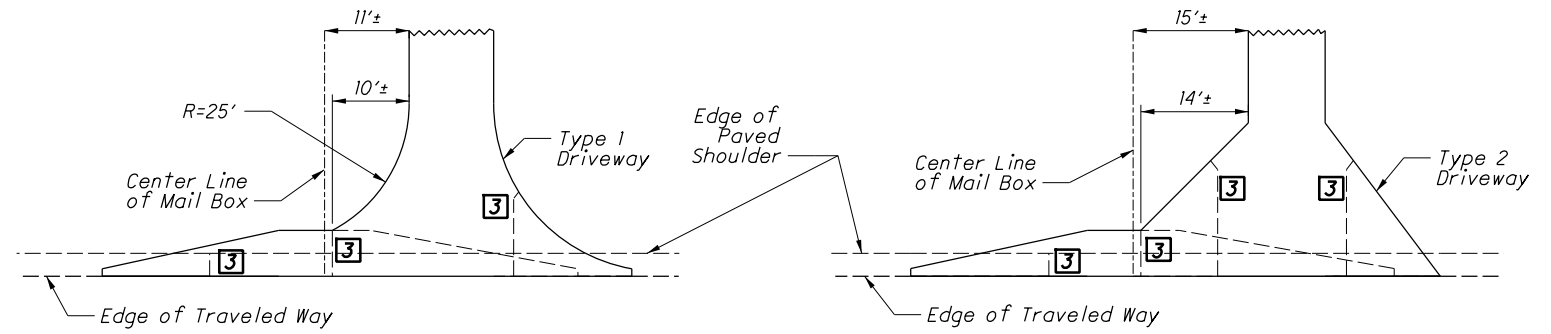

COMBINED DRIVEWAY & MAIL BOX APPROACH

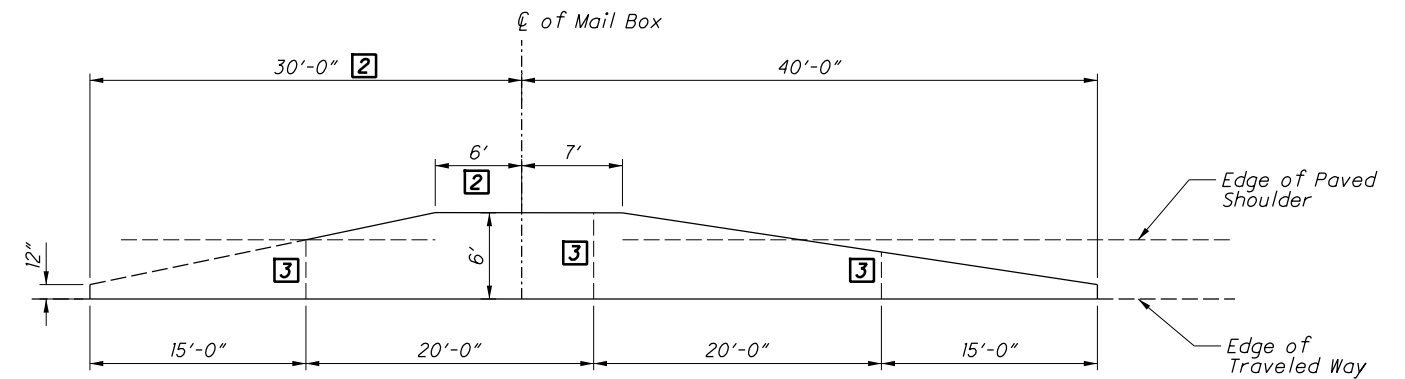

TYPICAL MAIL BOX APPROACH

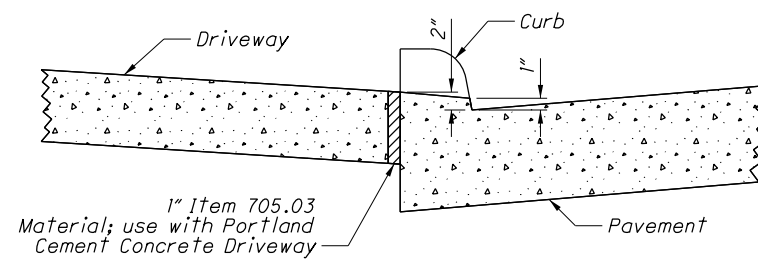

DROP CURB DETAILS AT DRIVEWAYS

Delta	A	B
80° to 90°	20'	20'
75° to 85°	25'	16'
65° to 75°	28'	13'
55° to 65°	33'	12'

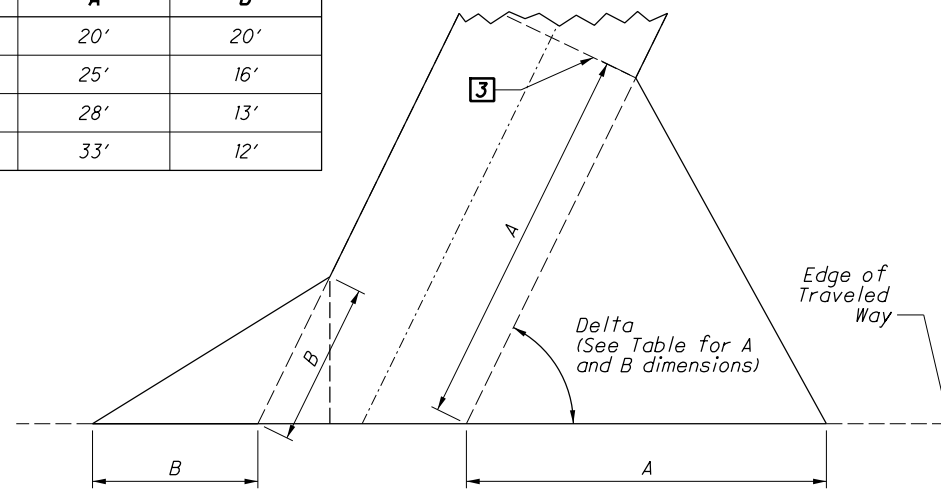

TYPE 2 SKEWED DRIVEWAY

Transition from Standard Curb Section to Drop Curb Section to be made in 18" distance from Driveway

NOTES

GENERAL: The design details shown here shall govern the construction of driveways unless otherwise shown in the project plans.

The pavement type and thickness shall be specified in the project plans.

Driveway and mail box approaches shall be combined when feasible.

JOINTS: Impressed joints for portland cement concrete driveways shall be 1/4" minimum width by 3"± depth and shall be sealed with Item 705.04 or ASTM D 1850.

In addition to the joints shown here, impressed joints without tie bars shall be placed in portland cement concrete driveways at intervals not to exceed 17' in the portion of the driveway beyond the flare.

LEGEND

- 1 Unless otherwise shown in the plans.
- 2 Add 3' for each additional Mail Box
- 3 Impressed Joint without Tie Bars for Portland Cement Surface

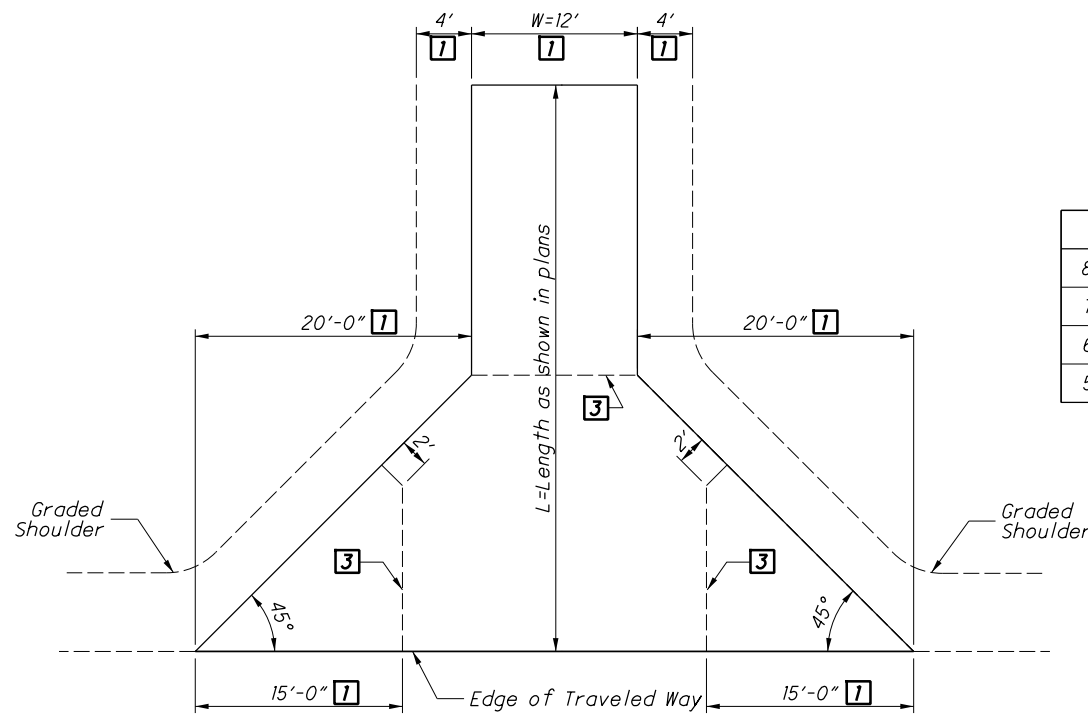

TYPE 2 DRIVEWAY

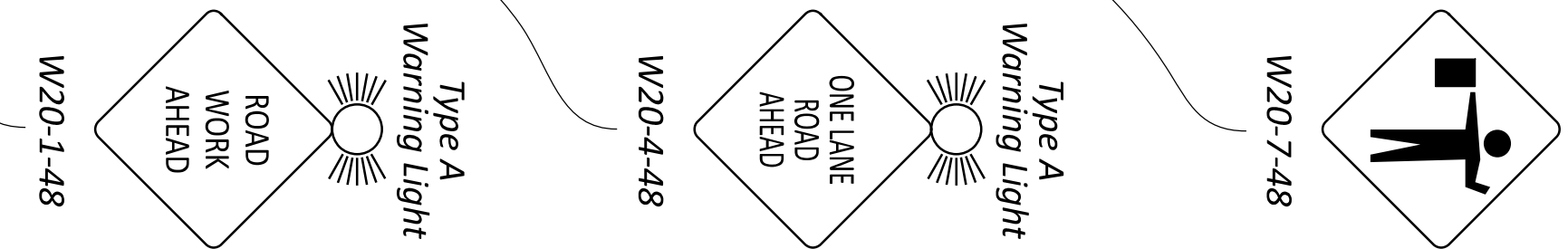
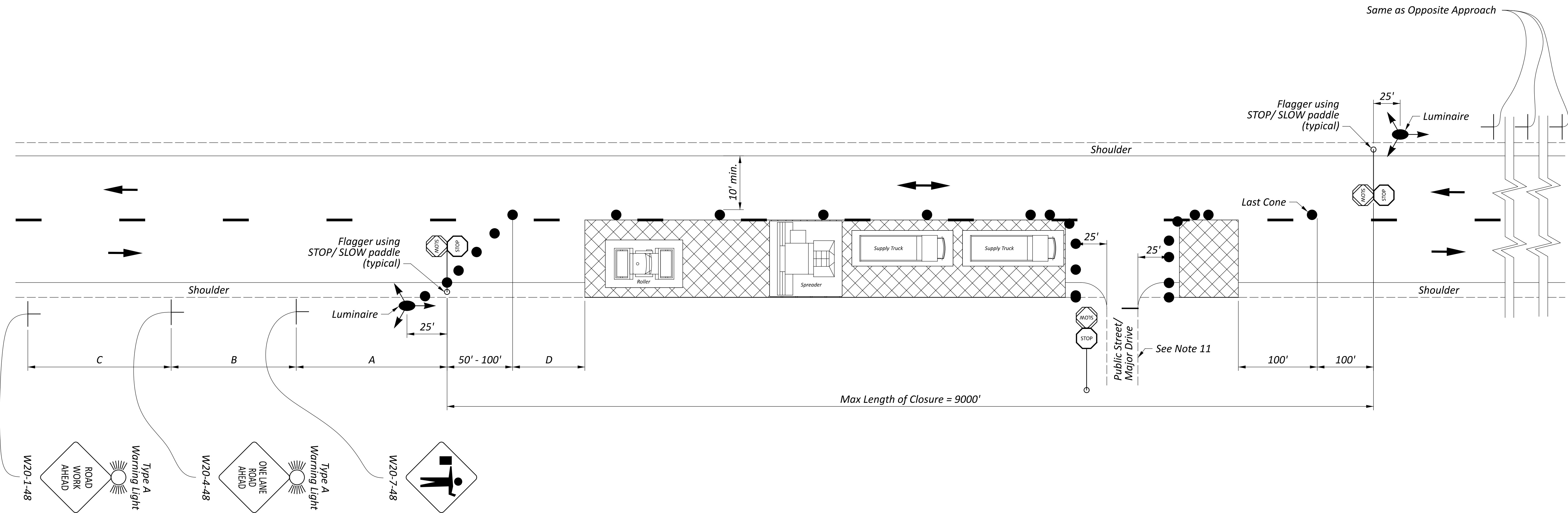
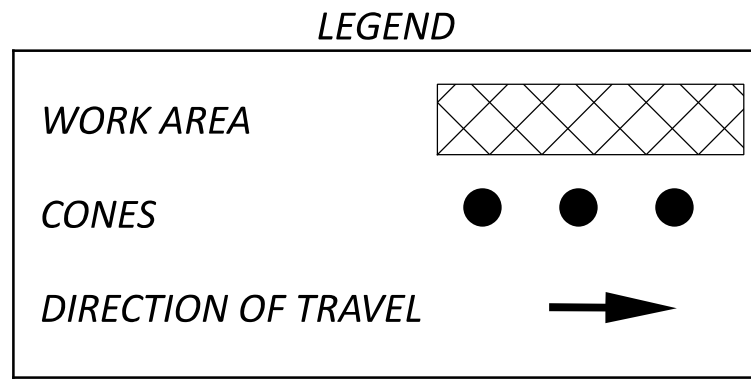

TABLE I (SIGN SPACING)

ROAD TYPE	DISTANCE BETWEEN SIGNS (FT)		
	A	B	C
Two-Lane (≤ 40 MPH)	100	100	100
Two-Lane (45-50 MPH)	350	350	350
Two-Lane (55-60 MPH)	500	500	500

TABLE II

SPEED LIMIT (MPH)	BUFFER (D) (FT) MIN.
25	155
30	200
35	250
40	305
45	360
50	425
55	495
60	570



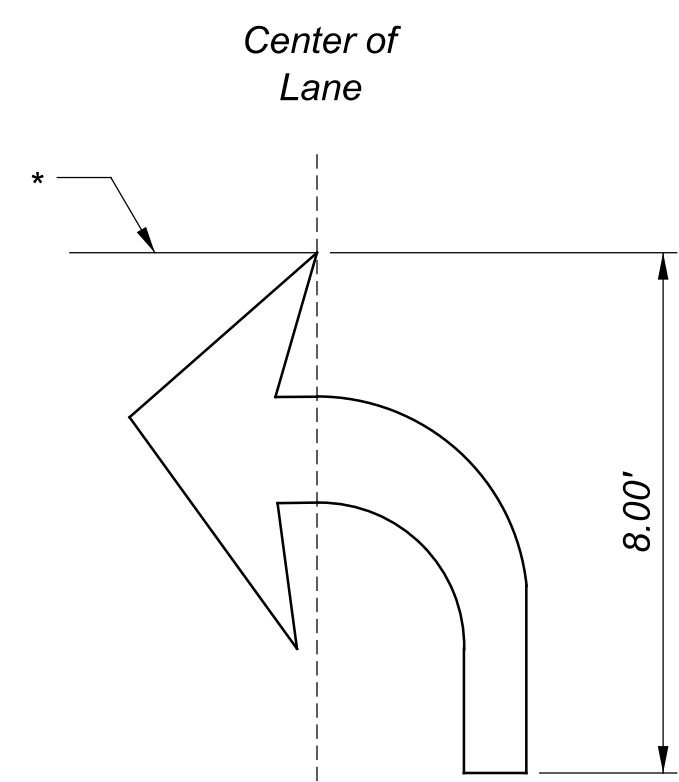

TURN ARROW
 (Right Arrow Opposite)

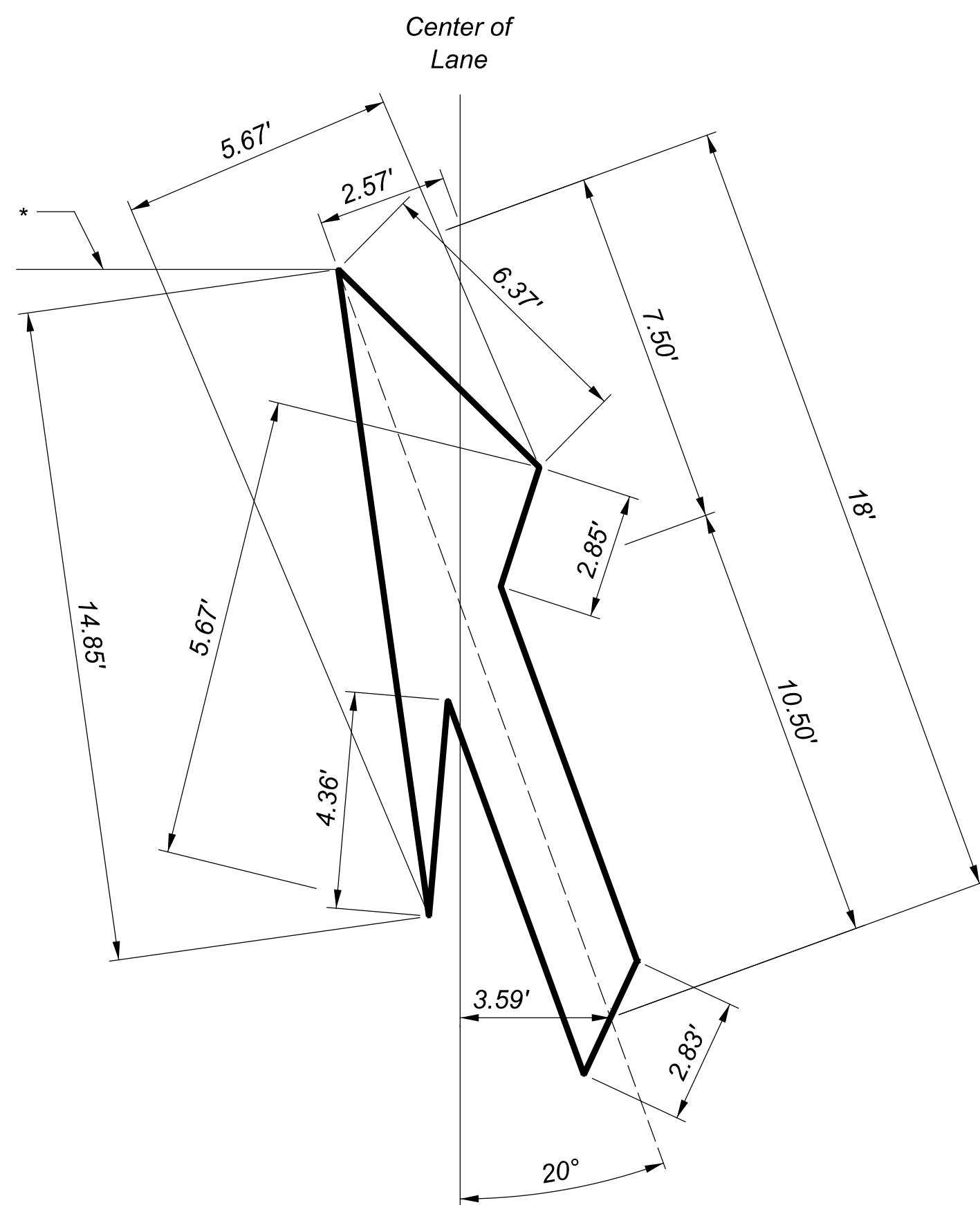

LANE-REDUCTION ARROW (RIGHT)
 (For Left Lane, Use Mirror Image)

TABLE 1 - LANE-USE ARROWS

ARROW TYPE	SIZE (FT)	AREA (SQ FT)
Turn Arrow	8.00	17
Through Arrow	9.50	13
Turn and Through Arrow	12.75	28
Lane-Reduction Arrow	18.00	46

* - Indicates Station Reference Point

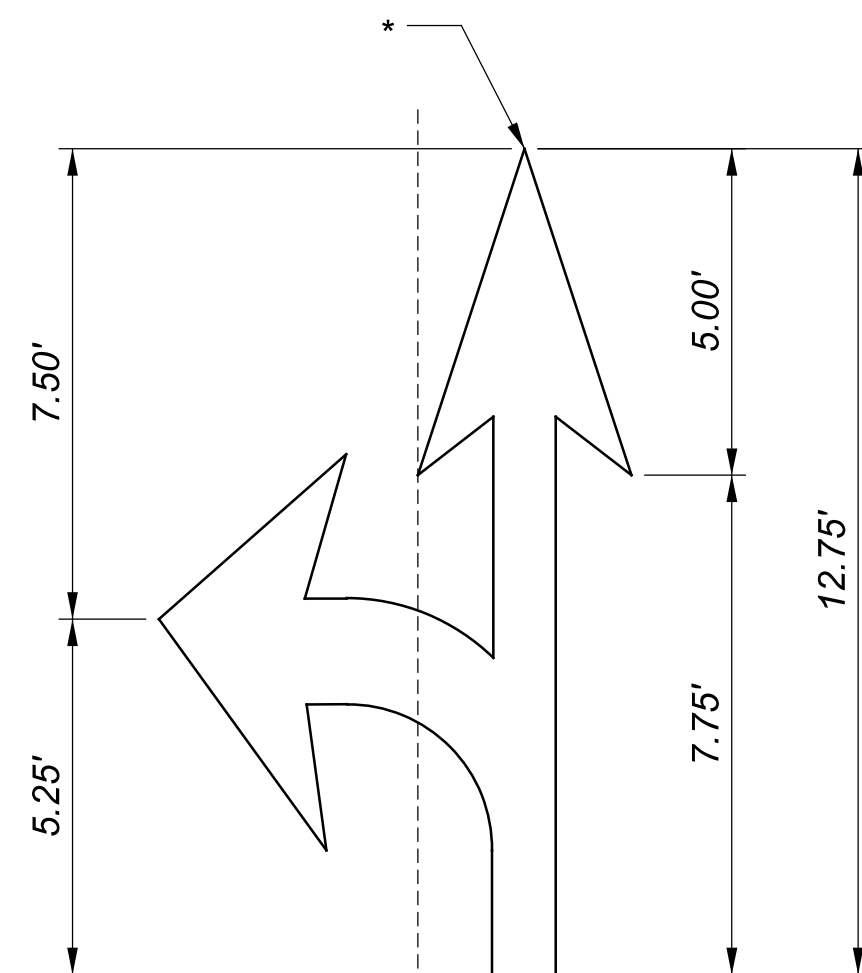

TURN AND THROUGH ARROW

(Three-Headed Directional Arrows Can be Achieved by the Combination of Turn Arrows.)

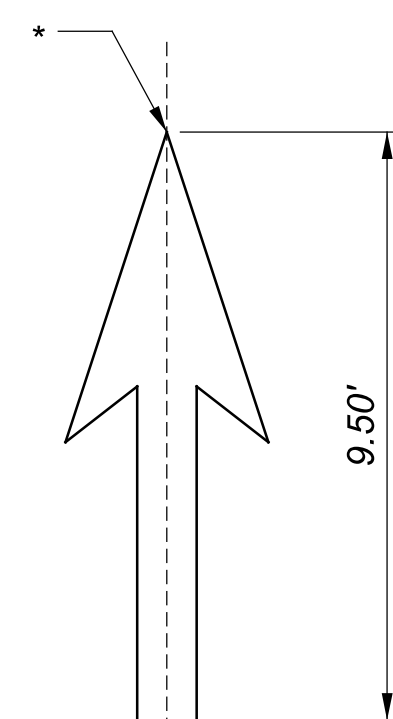

THROUGH ARROW

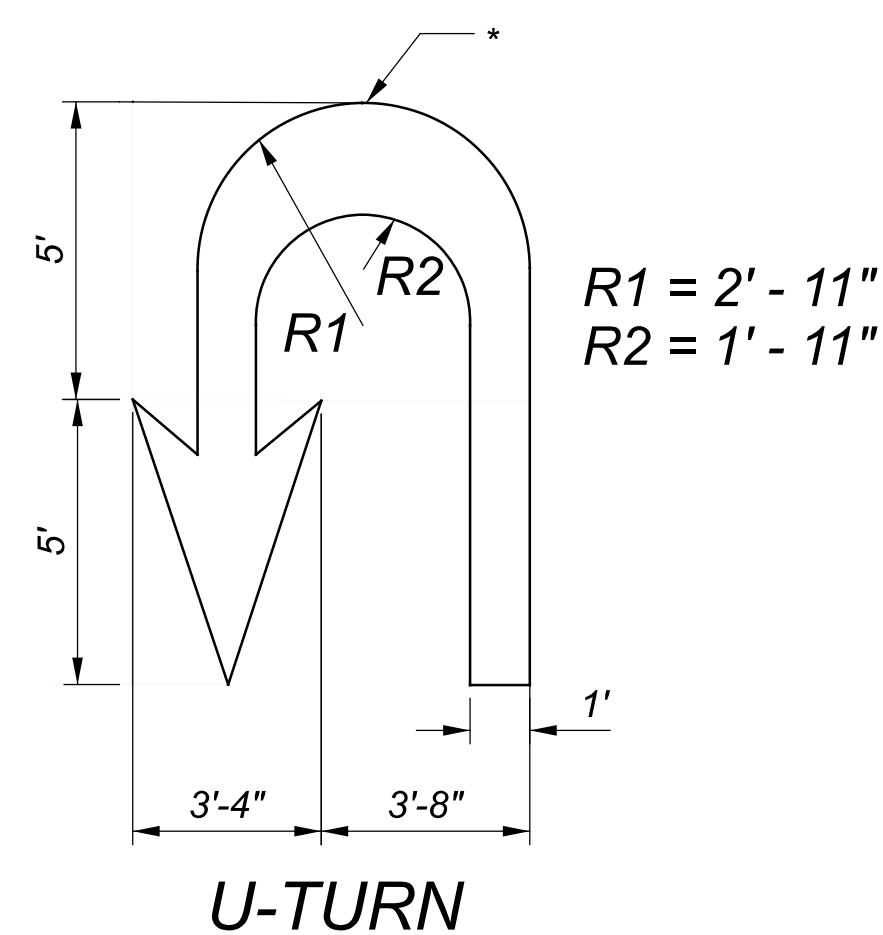

U-TURN

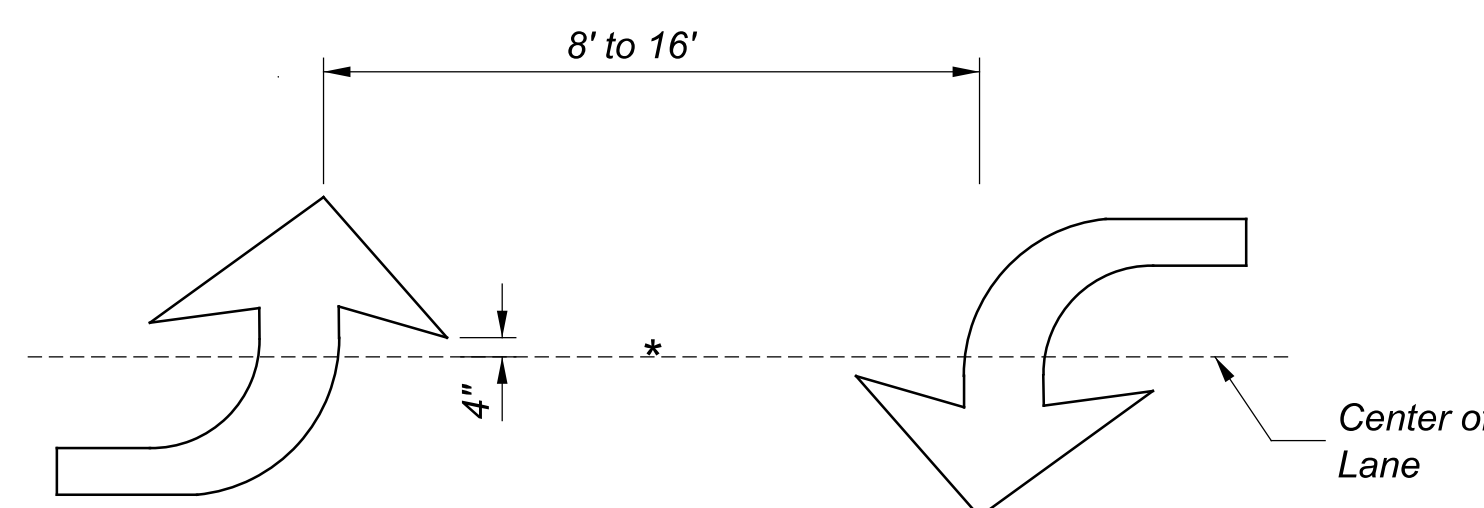

TWO-WAY LEFT-TURN ARROWS

(See Note 6)

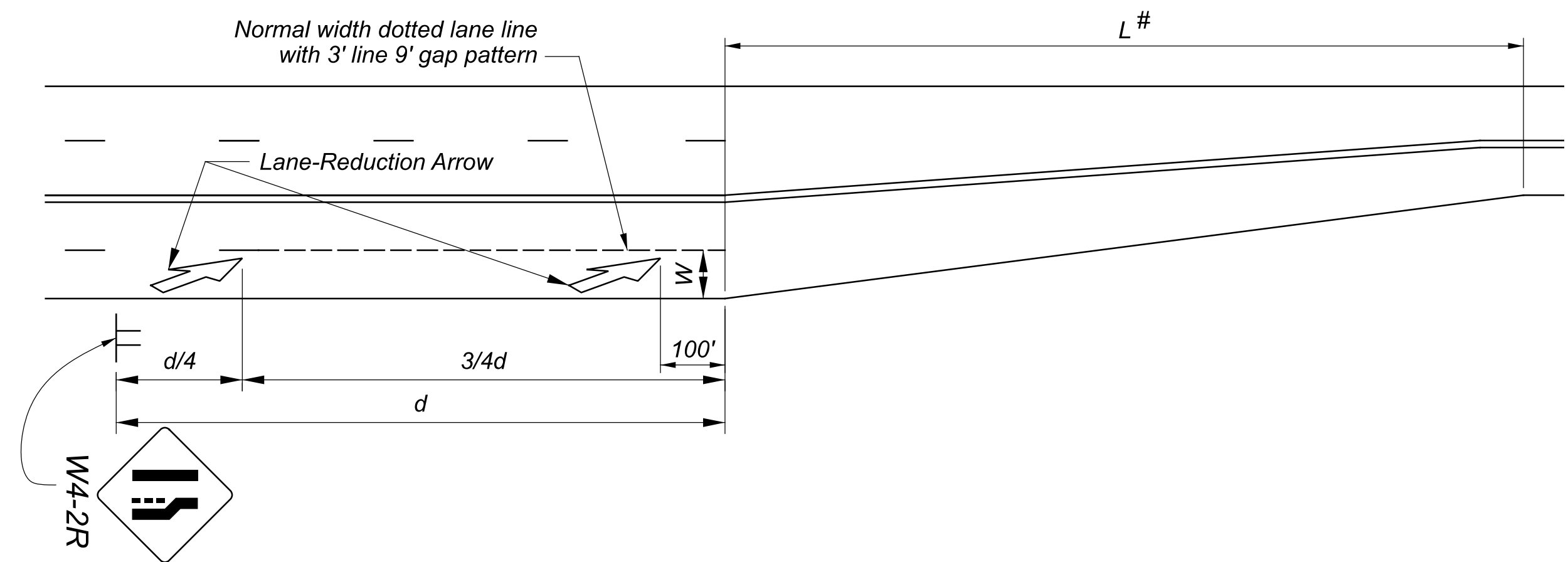

Speed (S) (MPH)	Lane Width (W) (FT)	Taper Length (L) # (FT)	Advance Warning Distance (d) (FT)
25	12	125	325
30	12	180	460
35	12	245	565
40	12	320	670
45	12	540	775
50	12	600	885
55	12	660	990
60	12	720	1100
65	12	780	1200
70	12	840	1250

LANE-REDUCTION ARROW MARKING DETAIL

(See Note 8)

Taper Length (L) shown is for 12 foot lane width (W).
 Use formula for other lane widths.

S - Posted, 85th-percentile or statutory speed, in MPH
 W - Lane width or offset, in feet

L - Taper length in feet for Speed < 45 MPH = $WS^2 / 60$
 L - Taper length in feet for Speed > 45 MPH = WS
 d - Advance Warning Distance, in feet

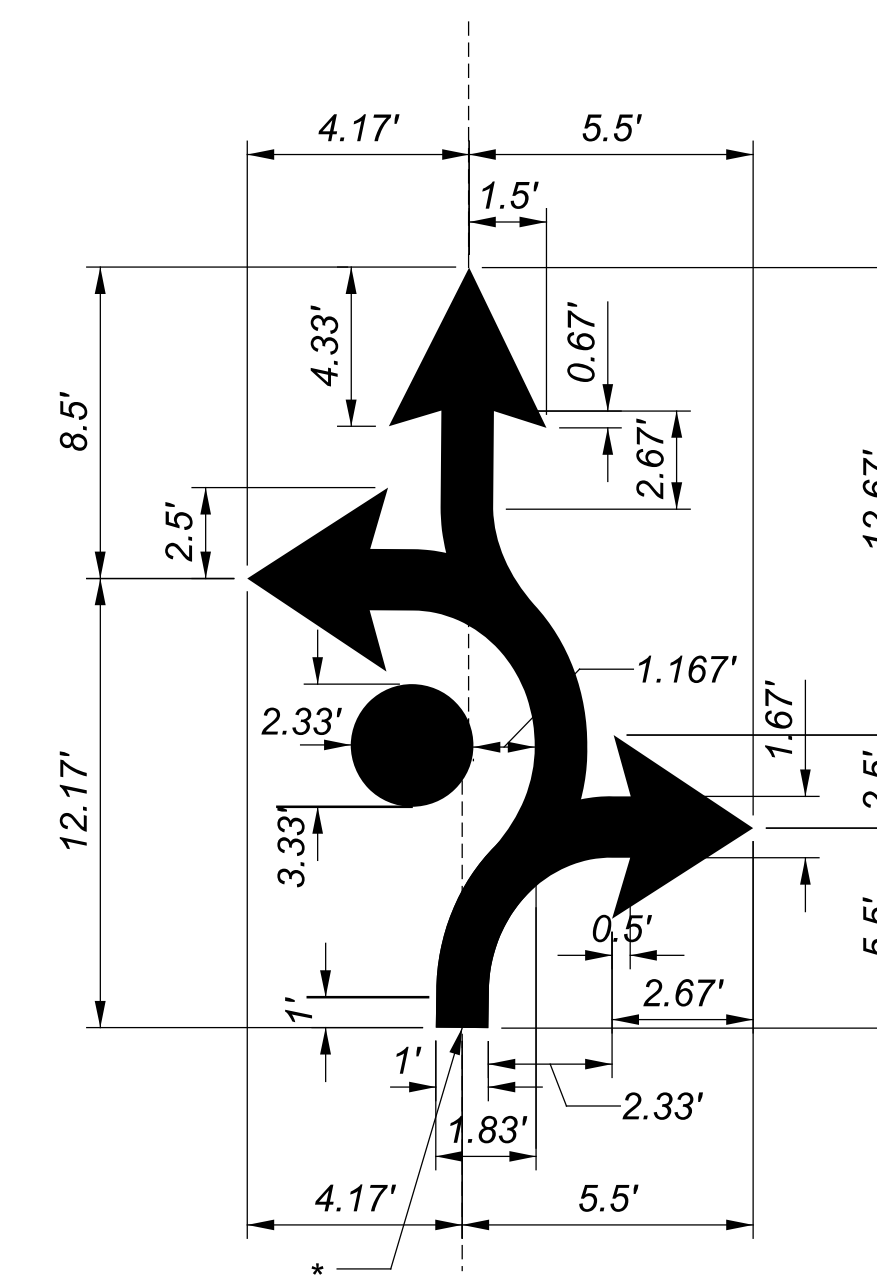

FISH-HOOK ARROW (ROUNDBABOUTS)

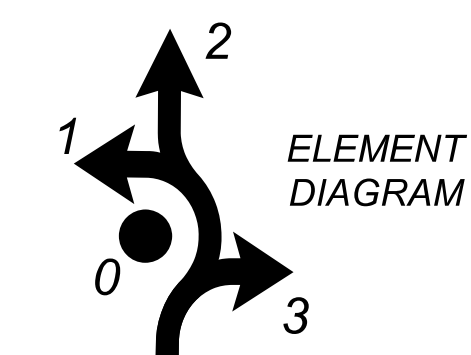

OVERALL DIMENSIONS		
ELEMENTS INCLUDED	OVERALL WIDTH	OVERALL HEIGHT
1	6.5'	14.67'
1 & 2	6.5'	20.67'
1 & 3	9.67'	14.67'
1, 2 & 3	9.67'	20.67'
0 & 2*	4.5'	20.67'
0, 2 & 3*	7.67'	20.67'
2	3.833'	20.67'
2 & 3	7.0'	20.67'
3	6.0'	8.0'

* THE DOT (ELEMENT 0) IS ONLY USED IN SYMBOLS FOR THE LEFTMOST LANE.

TABLE 4 - LANE USE MARKINGS

ROADWAY TYPE	DIMENSIONS (FT)		
	A (MIN.)	B	C
RURAL	30	88	8
URBAN	10	66	6

(See Note 5)

SHARED-USE PATH AND BIKEWAY MARKINGS

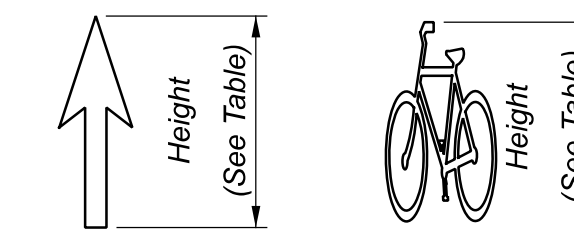
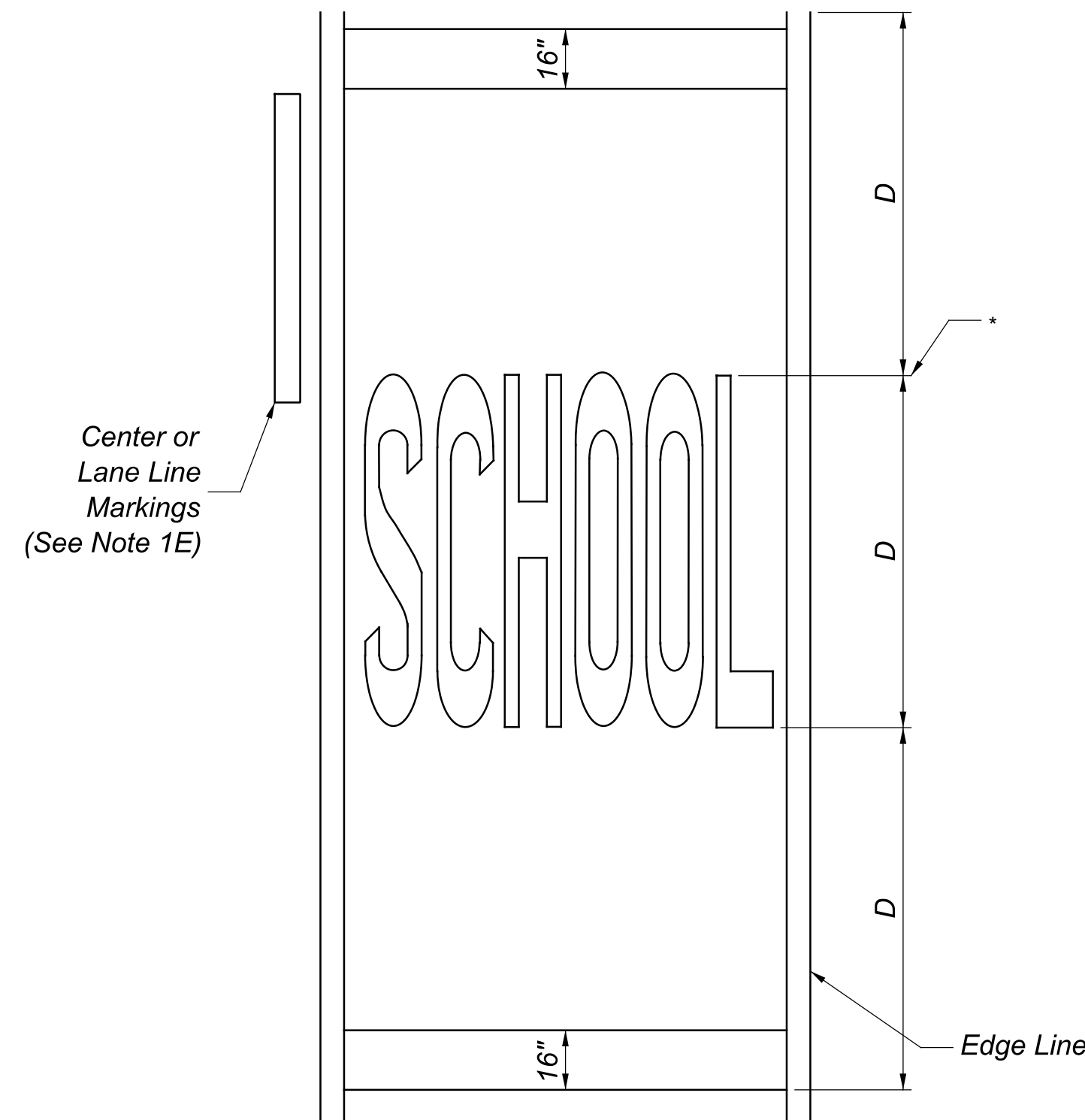
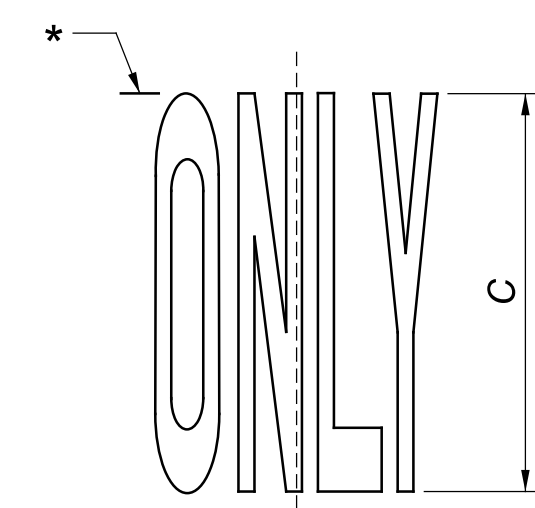

TABLE 1 - BIKEWAY MARKINGS

FACILITY TYPE	HEIGHT (FEET)	STRAIGHT ARROW	BIKE SYMBOL	HWY	XING	RXR SYMBOL
		AREA (SQUARE FEET)				
SHARED USE PATH	4	----	----	5	6	----
	10	----	----	----	----	16
BICYCLE LANE	6	6	5	----	16	----
ROADWAY-URBAN	6	5	5	----	16	----
ROADWAY-RURAL	8	7	7	----	21	----



SCHOOL WORD MARKING
 (See Note 1)



ONLY WORD MARKING
 (See Note 4)

TABLE 3 - WORDS (SQ FT)

WORD	HEIGHT (C, D)		
	URBAN	RURAL	MULTI-LANE
ONLY (C)	17	23	N/A
SCHOOL (D)	27	37	90

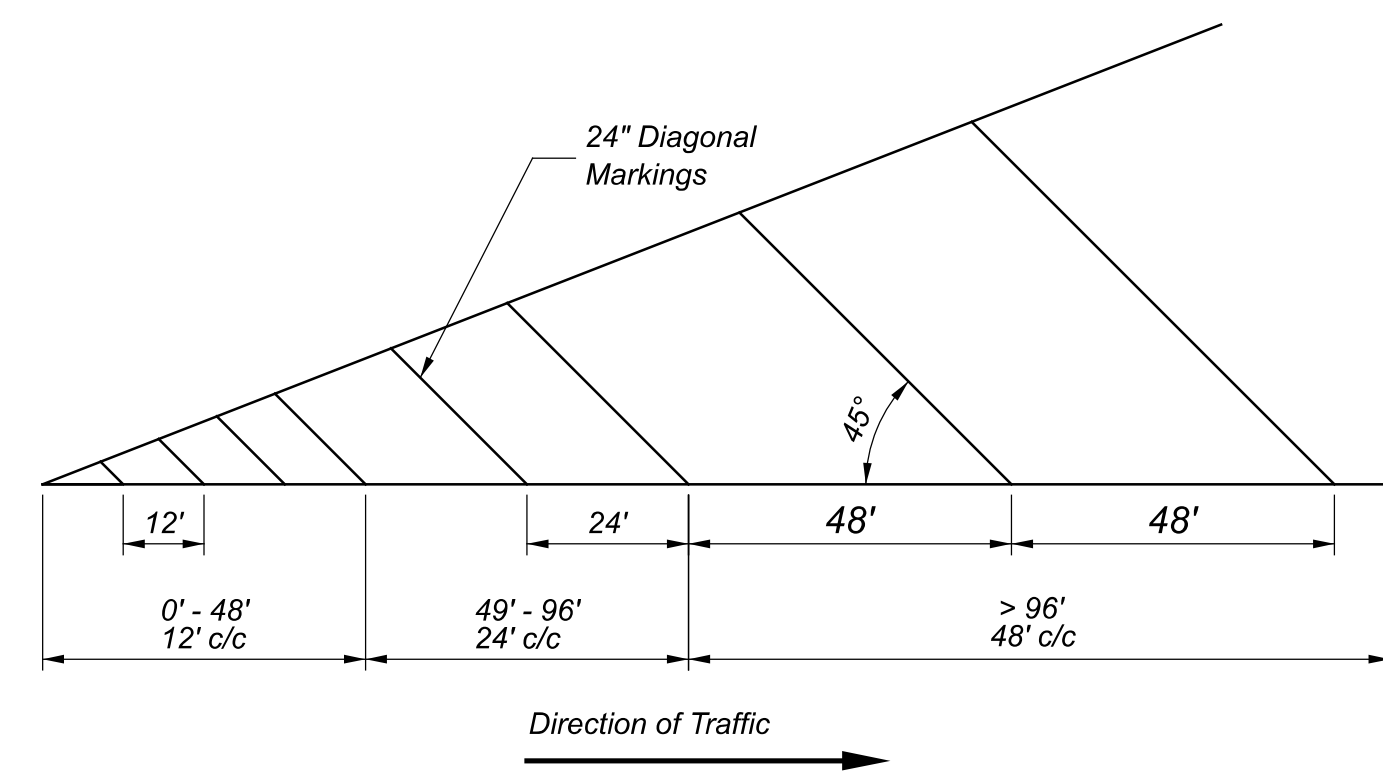

TYPICAL SPACING DETAIL FOR 24" DIAGONAL MARKINGS

(Chevron Markings, Including a Spacing Table, are Shown on SCD TC-72.20.)

* - Indicates Station Reference Point

TABLE 2 - HANDICAP, BIKE & CHEVRON MARKINGS

SYMBOL	HEIGHT (IN)	WIDTH (IN)	AREA (SQ FT)
HANDICAP	41	36	2.7
BIKE	72	40	16
CHEVRON	40	40	3.3 (.83 x 4)

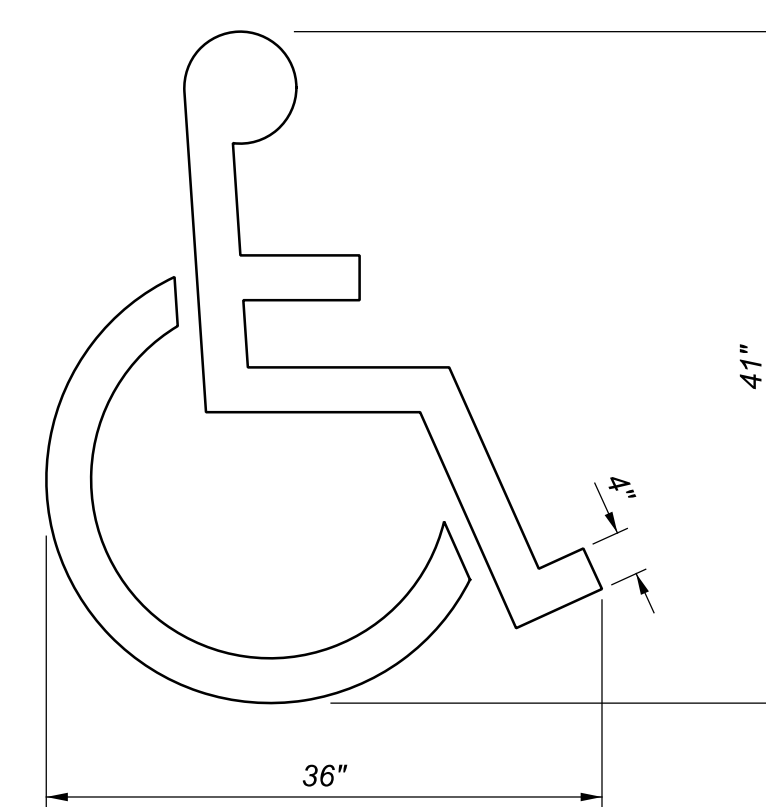

HANDICAP SYMBOL MARKING

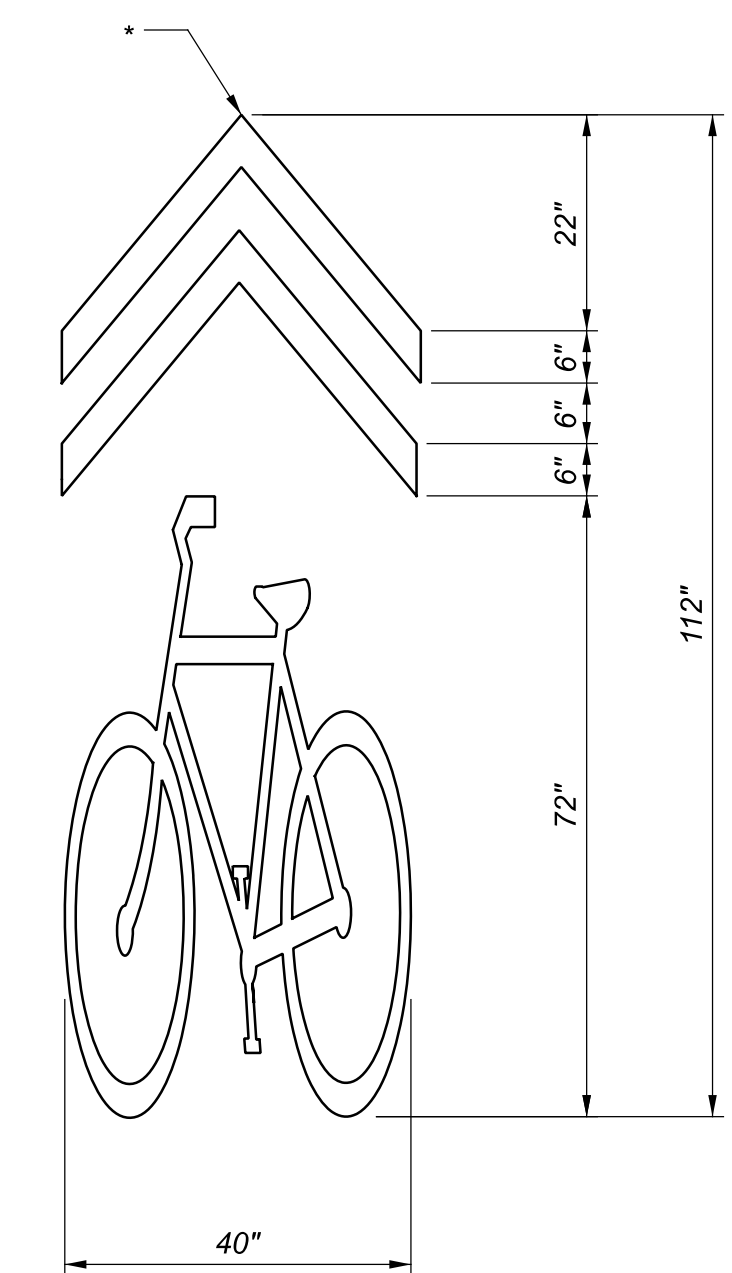

SHARED LANE MARKING
 (See Note 7)



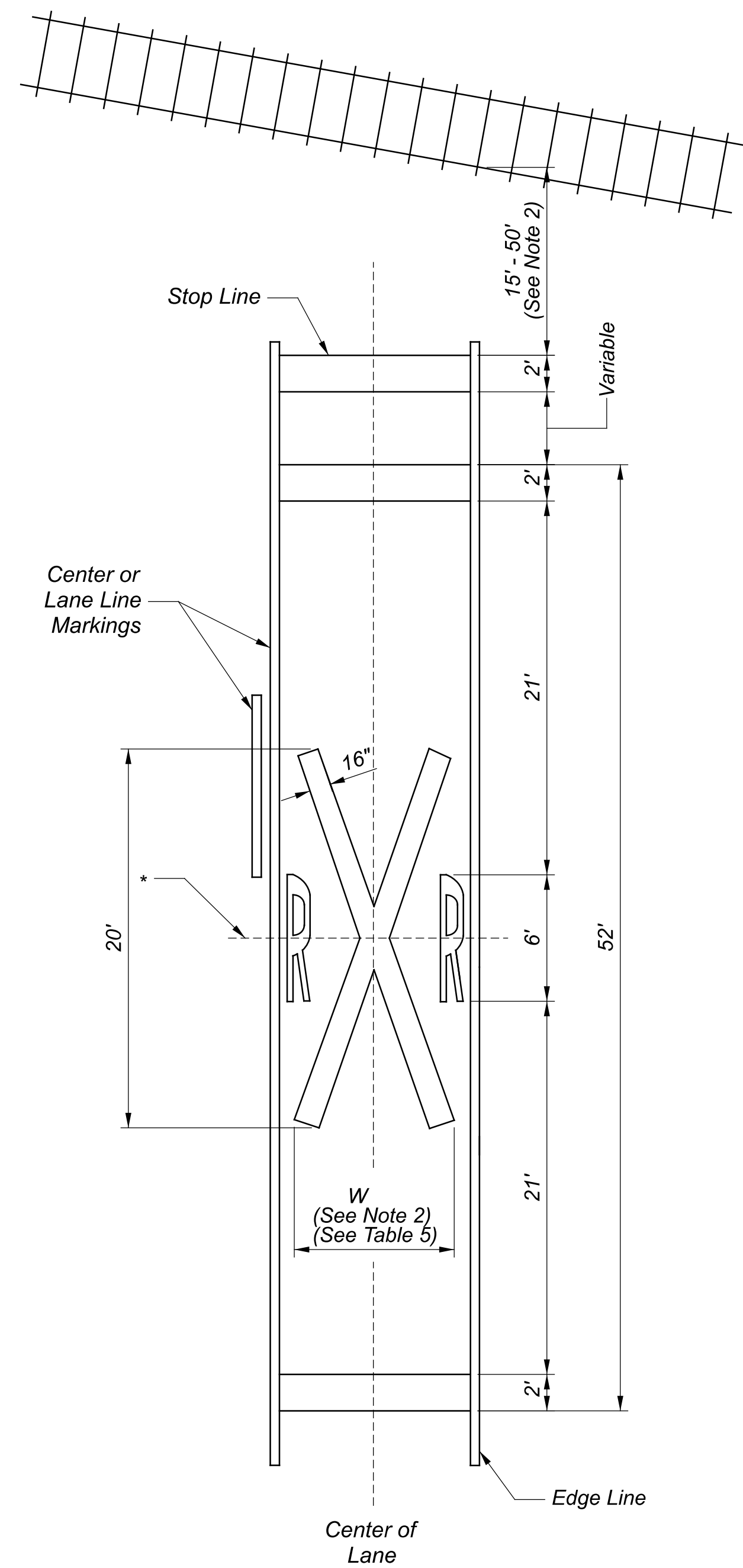

RAILROAD SYMBOL MARKING

(See Note 2)

TABLE 5 - R X R SYMBOL

	WIDTH (W) (FT)	8	9	10	11	12
	AREA (SQ FT)		67	68	70	71

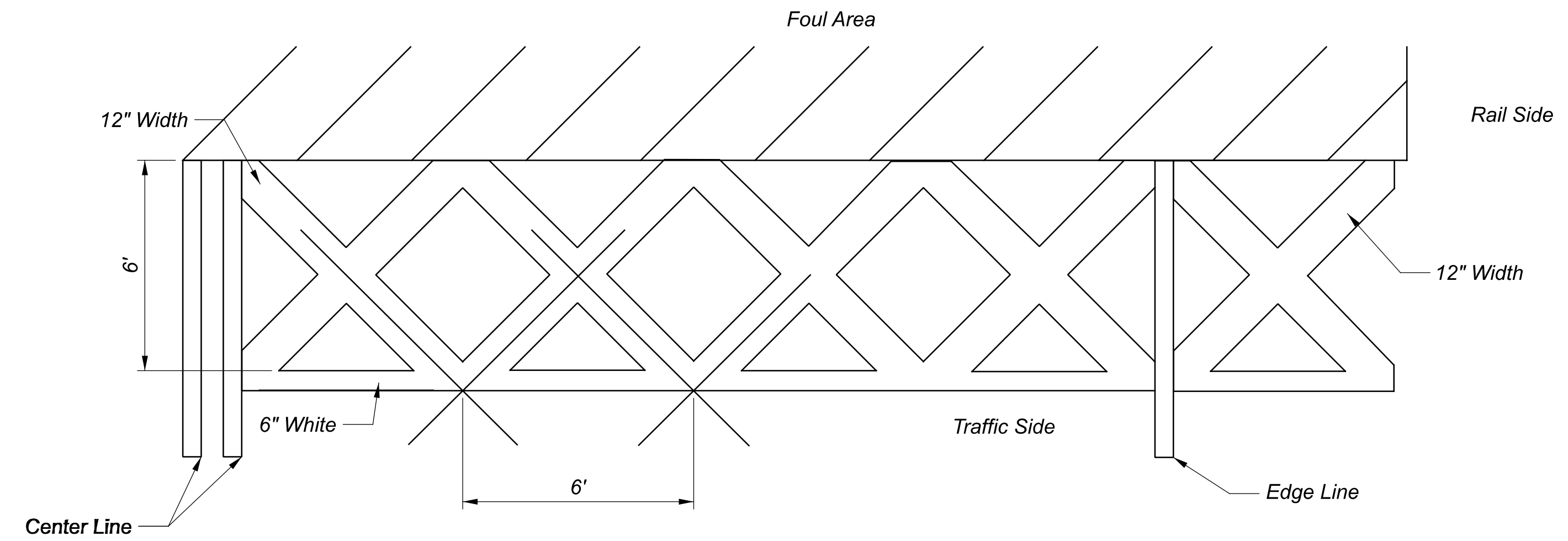

DYNAMIC ENVELOPE MARKINGS

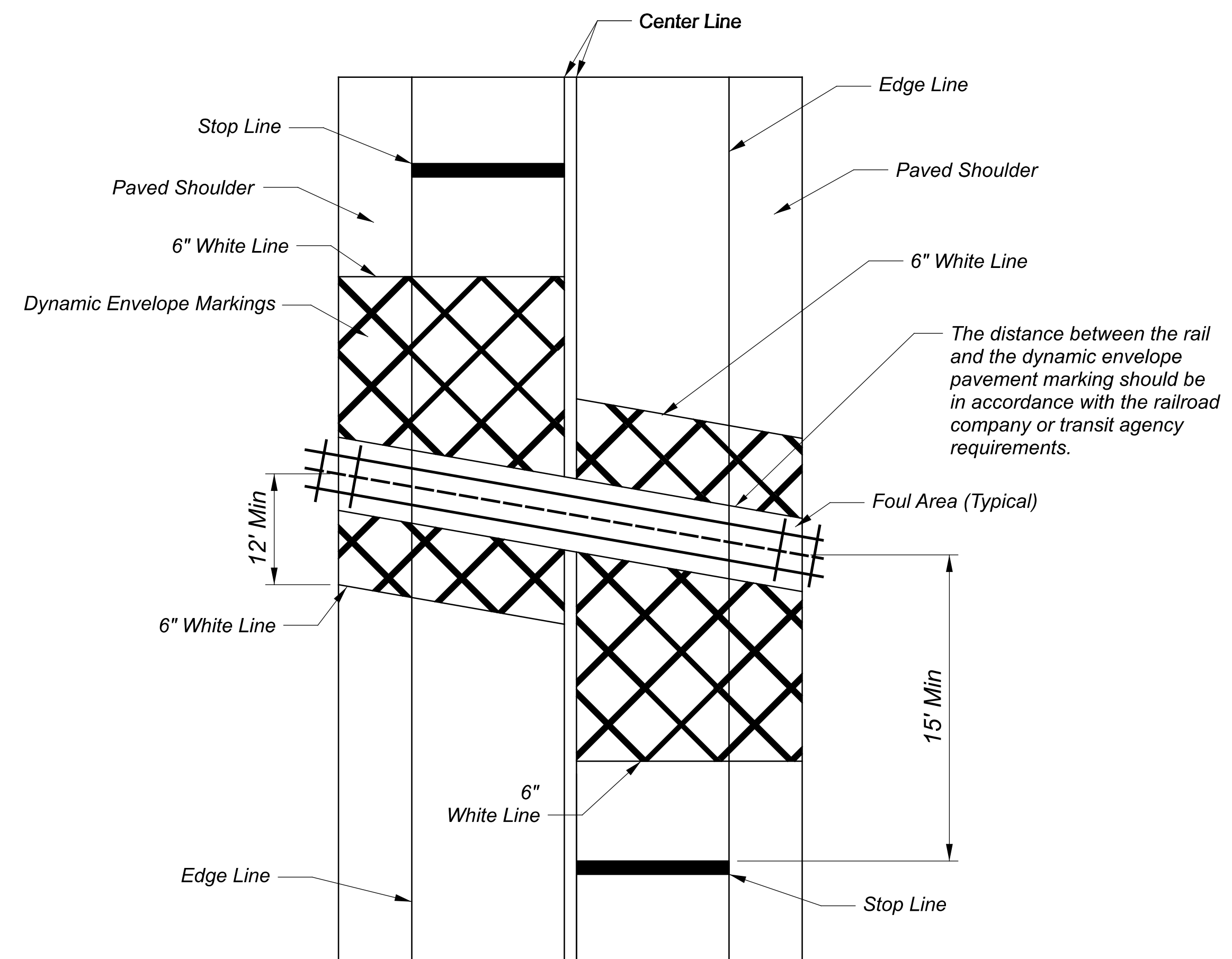

DYNAMIC ENVELOPE AND DO NOT OCCUPY INTERSECTION MARKINGS LAYOUT

NOTES:

SCHOOL Marking

- 1A. The SCHOOL markings shall be installed on all paved approaches in advance of all School Zones.
- 1B. The SCHOOL markings should be placed at least 100' in advance of the School Zone. The preferred placement of the SCHOOL marking is adjacent to the School Zone Advance sign.
- 1C. On two-way, two-lane highways the following shall apply:
 - 1.) When the approach lane to the School Zone is 11' or more in width -
 - a.) The SCHOOL word marking and transverse lines shall be contained in, and centered in, the lane.
 - b.) The character height shall be 6' for urban areas and 8' for rural areas.
 - 2.) When the approach lane to the School Zone is less than 11' in width -
 - a.) One installation of the SCHOOL word marking and transverse lines shall extend across both lanes of traffic.
 - b.) The characters shall be 10' in height.
- 1D. On multi-lane approaches the following shall apply -
 - 1.) When the approach lanes to the School Zone are 11' or more in width -
 - a.) The SCHOOL word marking and transverse lines shall be contained in, and centered in, each lane.
 - b.) The character height shall be 6' for urban areas and 8' for rural areas.
 - 2.) When the approach lanes to the School Zone are less than 11' in width -
 - a.) One installation of the SCHOOL word marking shall extend to the width of two approach lanes.
 - b.) Transverse lines shall extend across all approach lanes of traffic.
 - c.) The characters shall be 10' in height.
- 1E. Center or lane lines shall not pass through the SCHOOL word marking.
- 1F. 6' and 8' high SCHOOL word marking shall be marked with 4" strokes.

10' high SCHOOL word marking shall be marked with 8" strokes.
- 1G. The area of the transverse lines varies with the width of the pavement; therefore, the area must be added to the value in Table 3 (sheet 2).

Railroad Crossing Markings

- 2A. On multi-lane approaches, markings shall be as follows -
 - a.) The RXR symbol shall be placed in each approach lane.
 - b.) Transverse lines used with the railroad symbols shall extend across all approach lanes.
- 2B. The railroad symbol should be located so that the Railroad Advance Warning (W10-1) sign is within the two transverse boundary lines of the railroad symbol.
- 2C. The stop line shall be located for best sight distance between 15' - 50' of the near edge of the tracks.
- 2D. The stop line shall be approximately 8' from a gate (if present).
- 2E. Width (W) of the "X" will vary according to the lane width.
- 2F. The height of the "R" shall be 6'.
- 2G. The area of the transverse lines and stop lines varies with the width of the pavement; therefore the area must be added to the value in Table 5 (sheet 3).
- 2H. Dynamic Envelope Markings consist of a 6-inch white channelizing line placed a minimum of 6-feet away and parallel to the nearest outside edge of rail at a highway-rail grade crossing. The Dynamic Envelope Markings also consists of 12-inch white diagonal markings arranged at 6-foot centers in a 6-foot by 6-foot "X" layout (sheet 3).

Stop Line Marking

- 3A. Except as specified in Notes 3B and 3C, the stop line should be placed as follows:
 - a.) The stop line should be placed where cross-corner vision is maximum.
 - b.) In no case shall the stop line be placed more than 30' or less than 4' from the nearest edge of the intersecting roadway.
 - c.) For normal intersections the maximum distance should be 10'.
- 3B. If a marked crosswalk is present the stop line should be placed 4' in advance of, and parallel to, the nearest crosswalk line.
- 3C. For signalized intersections the stop line should be placed at a minimum distance of 40' from the nearest signal head.

ONLY Word Marking

- 4A. The ONLY word marking is optional.
- 4B. Where used, the spacing between ONLY and arrow markings should be based on Table 4 (sheet 2).
- 4C. When lane-use arrow markings are used and the ONLY marking is not, an additional lane-use arrow should be used in its place to retain the spacing as shown in Table 4 (sheet 2).

Lane-Use Arrow Markings

- 5A. Lane-use arrow markings are optional except where a through traffic lane(s) approaching an intersection becomes a mandatory turn lane(s).
- 5B. Where used, the spacing between markings should be based on Table 4 (sheet 2). However, based on the turn lane length, the spacing between the markings may be adjusted.

Two-Way Left-Turn Only (TWLTO) Arrows

- 6A. Arrow sets should be longitudinally spaced at intervals of:
 - a.) 500' - 1000' for speeds less than or equal to 40 mph,
 - b.) 1000' - 1500' for speeds over 40 mph
- 6B. In addition, an arrow set should be placed:
 - a.) 100' - 200' from the near edge of an intersecting roadway, or
 - b.) Inside both ends of TWLTO lanes.

Shared Lane Marking

- 7A. When chevron markings are used, its area must be added to the value of the bike symbol markings (see Table 2 on sheet 1).
- 7B. When used, the shared lane marking should be placed immediately after an intersection and spaced at intervals not greater than 250' thereafter.

Lane-Reduction Arrow Markings

- 8A. Lane-reduction arrow markings should be placed where a lane reduction transition occurs on a roadway as follows:
 - a.) Lane-reduction arrow markings may be placed for speeds of less than 45 mph, if determined to be appropriate based on engineering judgement.
 - b.) Lane-reduction arrow markings should be placed for speeds of 45 mph or over.
 - c.) Lane-reduction arrow markings may be placed in long acceleration lanes.
 - d.) Where lane-reduction arrows are used, they should be placed as follows:
 - i.) First lane-reduction arrow 100' in advance of the 'Begin Taper' point.
 - ii.) Second lane-reduction arrow placed at the 3/4d point.

Handicap Symbol Markings

- 9A. For the handicap symbol marking, a blue background and white border shall not be used.



**STATE
WAGE
RATES**

(2026)
Updated 04/21/2026

Prevailing Wage Determination Cover Letter

County:

Determination Date: 04-21-2026

Expiration Date: 07-19-2026

THE FOLLOWING PAGES ARE PREVAILING RATES OF WAGES ON PUBLIC IMPROVEMENTS FAIRLY ESTIMATED TO BE MORE THAN THE AMOUNT IN O.R.C. SEC. 4115.03 (b) (1) or (2), AS APPLICABLE.

Section 4115.05 provides, in part: "Where contracts are not awarded or construction undertaken within ninety days from the date of the establishment of the prevailing wages, there shall be a redetermination of the prevailing rate of wages before the contract is awarded." The expiration date of this wage schedule is listed above for your convenience only. This wage determination is not intended as a blanket determination to be used for all projects during this period without prior approval of this Department.

Section 4115.04, Ohio Revised Code provides, in part: "Such schedule of wages shall be attached to and made a part of the specifications for the work, and shall be printed on the bidding blanks where the work is done by contract..."

The contract between the letting authority and the successful bidder shall contain a statement requiring that mechanics and laborers be paid a prevailing rate of wage as required in Section 4115.06, Ohio Revised Code. The contractor or subcontractor is required to file with the contracting public authority upon completion of the project and prior to final payment therefore an affidavit stating that he has fully complied with Chapter 4115 of the Ohio Revised Code.

The wage rates contained in this schedule are the "Prevailing Wages" as defined by Section 4115.03, Ohio Revised Code (the basic hourly rates plus certain fringe benefits). These rates and fringes shall be a minimum to be paid under a contract regulated by Chapter 4115 of the Ohio Revised Code by contractors and subcontractors. The prevailing wage rates contained in this schedule include the effective dates and wage rates currently on file. In cases where future effective dates are not included in this schedule, modifications to the wage schedule will be furnished to the Prevailing Wage Coordinator appointed by the public authority as soon as prevailing wage rates increases are received by this office.

"There shall be posted in a prominent and accessible place on the site of work a legible statement of the Schedule of Wage Rates specified in the contract to the various classifications of laborers, workmen, and mechanics employed, said statement to remain posted during the life of such contract." Section 4115.07, Ohio Revised Code.

Apprentices will be permitted to work only under a bona fide apprenticeship program if such program exists and if such program is registered with the Ohio Apprenticeship Council.

Section 4115.071 provides that no later than ten days before the first payment of wages is due to any employee of any contractor or subcontractor working on a contract regulated by Chapter 4115, Ohio Revised Code, the contracting public authority shall appoint one of his own employees to act as the prevailing wage coordinator for said contract. The duties of the prevailing wage coordinator are outlined in Section 4115.071 of the Ohio Revised Code.

Section 4115.05 provides for an escalator in the prevailing wage rate. Each time a new rate is established, that rate is required to be paid on all ongoing public improvement projects.

A further requirement of Section 4115.05 of the Ohio Revised Code is: "On the occasion of the first pay date under a contract, the contractor shall furnish each employee not covered by a collective bargaining agreement or understanding between employers and bona fide organizations of Labor with individual written notification of the job classification to which the employee is assigned, the prevailing wage determined to be applicable to that classification, separated into the hourly rate of pay and the fringe payments, and the identity of the prevailing wage Coordinator appointed by the public authority. The contractor or subcontractor shall furnish the same notification to each affected employee every time the job classification of the employee is changed."

Work performed in connection with the installation of modular furniture may be subject to prevailing wage.

THIS PACKET IS NOT TO BE SEPARATED BUT IS TO REMAIN COMPLETE AS IT IS SUBMITTED TO YOU. (Reference guidelines and forms are included in this packet to be helpful in the compliance of the Prevailing Wage law.)

Prevailing Wage Rate Skilled Crafts

Name of Union: Bricklayer Local 23 Heavy Hwy (A)

Type of Rate: Commercial

Change #:
LCN01-2026ib

Craft:
Bricklayer

Effective Date:
3/25/2026

Effective Date:
3/25/2026

	BHR		Fringe Benefit Payments						Irrevocable Fund		Total PWR	Overtime Rate
			H&W	Pension	App Tr.	Vac.	Annuity	Other	LECET (*)	MISC (*)		
Classification												
Cement Mason Bricklayer Sewer Water Works A	\$34.56		\$10.20	\$9.68	\$0.56	\$0.00	\$1.30	\$0.00	\$0.00	\$0.00	\$56.30	\$73.58
Apprentice	BHR	Percent										
1st year	\$24.19	\$70.00	\$10.20	\$9.68	\$0.56	\$0.00	\$1.30	\$0.00	\$0.00	\$0.00	\$45.93	\$58.03
2nd year	\$27.65	\$80.00	\$10.20	\$9.68	\$0.56	\$0.00	\$1.30	\$0.00	\$0.00	\$0.00	\$49.39	\$63.21
3rd year	\$31.10	\$90.00	\$10.20	\$9.68	\$0.56	\$0.00	\$1.30	\$0.00	\$0.00	\$0.00	\$52.84	\$68.39

(*)Special Calculation Note :

This rate is not for building construction.

This rate applies only to the Cement Masons. All other Bricklaying, PCC, Stone, Tile, Marble, Refractory, Industrial and all other applicable work performed will be performed under the applicable rates for those contracts.

Ratio :

- 3 Journeymen to 1 Apprentice
- 6 Journeymen to 2 Apprentice
- 9 Journeymen to 3 Apprentice
- 12 Journeymen to 4 Apprentice
- 15 Journeymen to 5 Apprentice

Jurisdiction (* denotes special jurisdictional note) :

Adams, Allen, Ashland, Ashtabula, Athens, Auglaize, Belmont, Brown, Butler, Carroll, Champaign, Clark, Clermont, Clinton, Columbiana, Coshocton, Crawford, Cuyahoga, Darke, Defiance, Delaware, Erie, Fairfield, Fayette, Franklin, Fulton, Gallia, Geauga, Greene, Guernsey, Hamilton, Hancock, Hardin, Harrison, Henry, Highland, Hocking, Holmes, Huron, Jackson, Jefferson, Knox, Lake, Lawrence, Licking, Logan, Lorain, Lucas, Madison, Mahoning, Marion, Medina, Meigs, Mercer, Miami, Monroe, Montgomery, Morgan, Morrow, Muskingum, Noble, Ottawa, Paulding, Perry, Pickaway, Pike, Portage, Preble, Putnam, Richland, Ross, Sandusky, Scioto, Seneca, Shelby, Stark, Summit, Trumbull, Tuscarawas, Union, Van Wert, Vinton, Warren, Washington, Wayne

Special Jurisdictional Note :

Details :

Bricklayer Local 23 Heavy Hwy (A): Highway Construction, Sewer, Waterworks And Utility Construction, Industrial & Building Site Heavy Construction, Airport Construction Or Railroad Construction Work.

Bricklayer Local 23 Heavy Hwy (B): Power Plant, Tunnels, Amusement Park, Athletic Stadium Site Work ,Pollution Control, Sewer Plant, Waste Plant, & Water Treatment Facilities, Construction.

Prevailing Wage Rate Skilled Crafts

Name of Union: Carpenter Hev Hwy Zone NHH C1-B

Type of Rate: Commercial

Change #:
LCN01-2025ib

Craft:
Carpenter

Effective Date:
6/18/2025

Effective Date:
6/18/2025

	BHR		Fringe Benefit Payments					Irrevocable Fund		Total PWR	Overtime Rate	
			H&W	Pension	App Tr.	Vac.	Annuity	Other	LECET (*)			MISC (*)
Classification												
Carpenter	\$38.57		\$8.90	\$10.98	\$0.72	\$0.00	\$3.92	\$0.14	\$0.00	\$0.00	\$63.23	\$82.52
Apprentice	BHR	Percent										
1st 3 Months	\$23.14	\$60.00	\$8.90	\$0.00	\$0.00	\$0.00	\$0.00	\$0.00	\$0.00	\$0.00	\$32.04	\$43.61
2nd 3 Months	\$23.14	\$60.00	\$8.90	\$0.00	\$0.72	\$0.00	\$3.92	\$0.14	\$0.00	\$0.00	\$36.82	\$48.39
2nd 6 Months	\$25.07	\$65.00	\$8.90	\$0.00	\$0.72	\$0.00	\$3.92	\$0.14	\$0.00	\$0.00	\$38.75	\$51.29
3rd 6 Months	\$27.00	\$70.00	\$8.90	\$0.00	\$0.72	\$0.00	\$3.92	\$0.14	\$0.00	\$0.00	\$40.68	\$54.18
4th 6 Months	\$28.93	\$75.00	\$8.90	\$0.00	\$0.72	\$0.00	\$3.92	\$0.14	\$0.00	\$0.00	\$42.61	\$57.07
5th 6 Months	\$30.86	\$80.00	\$8.90	\$8.78	\$0.72	\$0.00	\$3.92	\$0.14	\$0.00	\$0.00	\$53.32	\$68.74
6th 6 Months	\$32.78	\$85.00	\$8.90	\$9.33	\$0.72	\$0.00	\$3.92	\$0.14	\$0.00	\$0.00	\$55.79	\$72.19
7th 6 Months	\$34.71	\$90.00	\$8.90	\$9.88	\$0.72	\$0.00	\$3.92	\$0.14	\$0.00	\$0.00	\$58.27	\$75.63
8th 6 Months	\$36.64	\$95.00	\$8.90	\$10.43	\$0.72	\$0.00	\$3.92	\$0.14	\$0.00	\$0.00	\$60.75	\$79.07

(*)Special Calculation Note :

Other: Training

Ratio :

1 Journeymen to 1 Apprentice

Jurisdiction (* denotes special jurisdictional note) :

Ashtabula, Cuyahoga, Geauga, Lake

Special Jurisdictional Note :

Details :

Any construction work as performed within the definitions listed here below, all of which, taken together are "Heavy-Highway Construction" work: "HIGHWAY CONSTRUCTION" work is defined as work performed to provide a facility to accommodate vehicular or pedestrian traffic and includes, but is not limited to, the construction of all streets, roads, expressways, turnpikes, bridges, drainage structures, grade separations, parking lots, rest areas, alleys, sidewalks, guardrails, fences, and sound barriers, but shall not include construction of buildings. "AIRPORT CONSTRUCTION" work is defined as including site preparation, grading, paving, drainage, fences, sidewalks, driveways, parking areas and similar work incidental to the construction of airfields but shall not include the construction of buildings. "HEAVY CONSTRUCTION" work is defined as including, but not limited to grade separations, foundations (does not include building foundations), abutments, retaining walls, shafts, tunnels, subways, elevators, drainage projects, flood control projects, reclamation projects, reservoirs, water supply projects, water development projects, hydro-electric development, utility transmission lines, including right-of-way clearing, locks, dams, dikes, levees, revetments, channels, channel cutoffs, intakes, dredging projects, jetties, breakwater, docks, harbors; and all municipal and utility construction except construction classified as building construction. "RAILROAD CONSTRUCTION" work is defined as including, grading, drainage, placing of rails, crossties, ballast and the construction of bridges, and other incidentals for railroads, street railways construction projects and rapid transit system projects, but shall not include the construction of buildings. "SEWER WATERWORKS AND UTILITY CONSTRUCTION" work is defined as including construction of all storm sewers, sanitary sewers, supplying and distributing waterlines, gas lines, telephone and television conduit, underground electrical lines, and similar utility construction. Main waterline and trunk sewers connecting water works and/or sewage disposal plants are included within this definition. "SUPPORTIVE EXCAVATION AND DEEP FOUNDATIONS" work is all driven and drilled foundations within the building site. "POWER PLANT SITE" work is defined as all work which is inside the property line, but outside the actual building construction. Such work shall include, but is not limited to, the grading and installation of sewer lines, drainage lines, gas lines, telephone and television conduit, underground electrical lines and similar utility construction, parking lots, bridges, roads, streets, sidewalks, reservoirs, ash pits, storage tanks, ramps and other such construction work performed on the work site, but shall not include the actual excavation for the buildings, foundations or footers or construction of the buildings. "POLLUTION CONTROL, SEWAGE PLANT, WASTE PLANT AND WATER TREATMENT FACILITIES CONSTRUCTION" WORK shall be all work in construction of pumping stations, waste and sewage disposal plants, incinerator plants, water treatment plants, filtration plants, solid waste disposal and similar pollution control facilities. "SOLAR & WIND FARM" WORK is considered "HEAVY CONSTRUCTION" and includes all work in the construction of solar fields/farms and wind fields/farms (not installations on buildings).

Prevailing Wage Rate Skilled Crafts

Name of Union: Carpenter Pile Driver Hev Hwy Zone NHH P2-B

Type of Rate: Commercial

Change #:
LCN01-2025ib

Craft:
Carpenter

Effective Date:
6/18/2025

Effective Date:
6/18/2025

	BHR		Fringe Benefit Payments					Irrevocable Fund		Total PWR	Overtime Rate	
			H&W	Pension	App Tr.	Vac.	Annuity	Other	LECET (*)			MISC (*)
Classification												
Carpenter Pile Driver	\$36.34		\$8.85	\$11.33	\$0.72	\$0.00	\$6.48	\$0.19	\$0.00	\$0.00	\$63.91	\$82.08
Diver	\$54.51		\$8.85	\$11.33	\$0.72	\$0.00	\$6.48	\$0.19	\$0.00	\$0.00	\$82.08	\$109.34
Certified Welder	\$37.39		\$8.85	\$11.33	\$0.72	\$0.00	\$6.48	\$0.19	\$0.00	\$0.00	\$64.96	\$83.66
Apprentice	BHR	Percent										
1st 6 months	\$21.80	\$60.00	\$8.85	\$11.33	\$0.72	\$0.00	\$6.48	\$0.19	\$0.00	\$0.00	\$49.37	\$60.28
2nd 6 months	\$23.62	\$65.00	\$8.85	\$11.33	\$0.72	\$0.00	\$6.48	\$0.19	\$0.00	\$0.00	\$51.19	\$63.00
3rd 6 months	\$25.44	\$70.00	\$8.85	\$11.33	\$0.72	\$0.00	\$6.48	\$0.19	\$0.00	\$0.00	\$53.01	\$65.73
4th 6 months	\$27.26	\$75.00	\$8.85	\$11.33	\$0.72	\$0.00	\$6.48	\$0.19	\$0.00	\$0.00	\$54.83	\$68.45
5th 6 months	\$29.07	\$80.00	\$8.85	\$11.33	\$0.72	\$0.00	\$6.48	\$0.19	\$0.00	\$0.00	\$56.64	\$71.18
6th 6 months	\$30.89	\$85.00	\$8.85	\$11.33	\$0.72	\$0.00	\$6.48	\$0.19	\$0.00	\$0.00	\$58.46	\$73.90
7th 6 months	\$32.71	\$90.00	\$8.85	\$11.33	\$0.72	\$0.00	\$6.48	\$0.19	\$0.00	\$0.00	\$60.28	\$76.63
8th 6 months	\$34.52	\$95.00	\$8.85	\$11.33	\$0.72	\$0.00	\$6.48	\$0.19	\$0.00	\$0.00	\$62.09	\$79.35

(*)Special Calculation Note :

*Other is Training

Ratio :

1 Journeymen to 1 Apprentice

Jurisdiction (* denotes special jurisdictional note) :

Ashland, Ashtabula, Cuyahoga, Erie, Geauga, Huron, Lake, Lorain, Medina, Portage, Richland, Summit

Special Jurisdictional Note :

Details :

Pile Drivers duties shall include but not limited to: Pile driving, milling, fashioning, joining assembling, erecting, fastening, or dismantling of all material of wood, plastic, metal, fiber, cork and composition and all other substitute materials: pile driving, cutting, fitting and placing of lagging, and the handling, cleaning, erecting, installing and dismantling of machinery, equipment and erecting pre-engineered metal buildings. Pile Drivers work but not limited to: unloading, assembling, erection, repairs, operation, signaling, dismantling and reloading all equipment that is used for pile driving including pile butts is defined as sheeting or scrap piling. Underwater work that may be required in connection with the installation of piling. The driver and his tender work as a team and shall arrive at their own financial arrangements with the contractor. Any configuration of wood, steel, concrete or composite that is jetted, driven or vibrated onto the ground by conventional pile driving equipment for the purpose of supporting a future load that may be permanent or temporary. The construction of all wharves and docks, including the fabrication and installation of floating docks. Driving bracing, plumbing, cutting off and capping of all piling whether wood, metal, pipe piling or composite, loading, unloading, erecting, framing, dismantling, moving and handling of pile driving equipment piling used in the construction and repair of all wharves, docks, piers, trestles, caissons, cofferdams and erection of all sea walls and breakwaters. All underwater and marine work on bulkheads, wharves, docks, shipyards, caissons, piers, bridges, pipeline, work, viaducts, marine cable and trestles, as well as salvage and reclamation work where divers are employed. Rate shall include carpenters, acoustic and ceiling installers, drywall installers, pile drivers and floorlayers.

Prevailing Wage Rate Skilled Crafts

Name of Union: Cement Mason Local 404 Hev Hwy

Type of Rate: Commercial

Change #:
LCN01-2025ib

Craft:
Cement Mason

Effective Date:
5/1/2025

Effective Date:
5/1/2025

	BHR		Fringe Benefit Payments						Irrevocable Fund		Total PWR	Overtime Rate
			H&W	Pension	App Tr.	Vac.	Annuity	Other	LECET (*)	MISC (*)		
Classification												
Cement Mason	\$36.29		\$9.20	\$7.85	\$0.75	\$0.00	\$3.00	\$0.07	\$0.00	\$0.00	\$57.16	\$75.31
Apprentice	BHR	Percent										
1st Year	\$25.40	\$70.00	\$9.20	\$7.85	\$0.75	\$0.00	\$3.00	\$0.07	\$0.00	\$0.00	\$46.27	\$58.97
2nd Year	\$29.03	\$80.00	\$9.20	\$7.85	\$0.75	\$0.00	\$3.00	\$0.07	\$0.00	\$0.00	\$49.90	\$64.42
3rd Year	\$32.66	\$90.00	\$9.20	\$7.85	\$0.75	\$0.00	\$3.00	\$0.07	\$0.00	\$0.00	\$53.53	\$69.86
4th Year	\$34.48	\$95.00	\$9.20	\$7.85	\$0.75	\$0.00	\$3.00	\$0.07	\$0.00	\$0.00	\$55.35	\$72.58

(*)Special Calculation Note :

Other: International Training Fund

Ratio :

1 Journeyman to 1 Apprentice 2 Journeymen to 1 Apprentice thereafter

Jurisdiction (* denotes special jurisdictional note) :

Ashtabula, Cuyahoga, Geauga, Lake, Lorain

Special Jurisdictional Note :

Details :

Highway Construction, Sewer, Waterworks And Utility Construction, Industrial & Building Site, Heavy Construction, Airport Construction Or Railroad Construction Work, Power Plant, Tunnels, Amusement Park, Athletic Stadium Site Work, Pollution Control, Sewer Plant, Waste & Water Plant, Water Treatment Facilities Construction.

Prevailing Wage Rate Skilled Crafts

Name of Union: Electrical Local 71 Outside Utility Power

Type of Rate: Commercial

Change #:
LCN01-2026ib

Craft:
Electrical

Effective Date:
1/7/2026

Effective Date:
1/7/2026

	BHR		Fringe Benefit Payments					Irrevocable Fund		Total PWR	Overtime Rate	
			H&W	Pension	App Tr.	Vac.	Annuity	Other	LECET (*)			MISC (*)
Classification												
Electrical Lineman	\$52.03		\$7.50	\$1.56	\$0.52	\$0.00	\$12.49	\$1.00	\$0.00	\$0.00	\$75.10	\$101.12
Substation Technician	\$52.03		\$7.50	\$1.56	\$0.50	\$0.00	\$12.49	\$1.00	\$0.00	\$0.00	\$75.08	\$101.09
Cable Splicer	\$54.50		\$7.50	\$1.64	\$0.55	\$0.00	\$13.08	\$1.00	\$0.00	\$0.00	\$78.27	\$105.52
Operator A	\$46.61		\$7.50	\$1.40	\$0.47	\$0.00	\$11.19	\$1.00	\$0.00	\$0.00	\$68.17	\$91.47
Operator B	\$41.17		\$7.50	\$1.23	\$0.41	\$0.00	\$9.87	\$1.00	\$0.00	\$0.00	\$61.18	\$81.77
Operator C	\$33.00		\$7.50	\$0.99	\$0.33	\$0.00	\$7.92	\$1.00	\$0.00	\$0.00	\$50.74	\$67.24
Groundman 0-12 months Exp	\$26.02		\$7.50	\$0.78	\$0.26	\$0.00	\$6.24	\$1.00	\$0.00	\$0.00	\$41.80	\$54.81
Groundman 0-12 months Exp w/CDL	\$28.62		\$7.50	\$0.86	\$0.29	\$0.00	\$6.87	\$1.00	\$0.00	\$0.00	\$45.14	\$59.45
Groundman 1 yr or more	\$28.62		\$7.50	\$0.86	\$0.29	\$0.00	\$6.87	\$1.00	\$0.00	\$0.00	\$45.14	\$59.45
Groundman 1 yr or more w/CDL	\$33.82		\$7.50	\$1.01	\$0.34	\$0.00	\$8.12	\$1.00	\$0.00	\$0.00	\$51.79	\$68.70
Equipment Mechanic A	\$41.17		\$7.50	\$1.23	\$0.41	\$0.00	\$9.87	\$1.00	\$0.00	\$0.00	\$61.18	\$81.77
Equipment Mechanic B	\$37.09		\$7.50	\$1.11	\$0.37	\$0.00	\$8.90	\$1.00	\$0.00	\$0.00	\$55.97	\$74.52
Equipment Mechanic C	\$33.00		\$7.50	\$0.99	\$0.33	\$0.00	\$7.92	\$1.00	\$0.00	\$0.00	\$50.74	\$67.24
Line Truck w/auger	\$36.40		\$7.50	\$1.09	\$0.36	\$0.00	\$8.71	\$1.00	\$0.00	\$0.00	\$55.06	\$73.26
Apprentice	BHR	Percent										
1st 1000 hrs	\$31.22	\$60.00	\$7.50	\$0.94	\$0.31	\$0.00	\$7.49	\$1.00	\$0.00	\$0.00	\$48.46	\$64.07
2nd 1000 hrs	\$33.82	\$65.00	\$7.50	\$1.01	\$0.34	\$0.00	\$8.12	\$1.00	\$0.00	\$0.00	\$51.79	\$68.70
3rd 1000 hrs	\$36.42	\$70.00	\$7.50	\$1.09	\$0.36	\$0.00	\$8.74	\$1.00	\$0.00	\$0.00	\$55.11	\$73.32

4th 1000 hrs	\$39.02	\$75.00	\$7.50	\$1.17	\$0.39	\$0.00	\$9.37	\$1.00	\$0.00	\$0.00	\$58.45	\$77.96
5th 1000 hrs	\$41.62	\$80.00	\$7.50	\$1.25	\$0.44	\$0.00	\$9.99	\$1.00	\$0.00	\$0.00	\$61.80	\$82.61
6th 1000 hrs	\$44.23	\$85.00	\$7.50	\$1.33	\$0.44	\$0.00	\$10.61	\$1.00	\$0.00	\$0.00	\$65.11	\$87.22
7th 1000 hrs	\$46.83	\$90.00	\$7.50	\$1.40	\$0.47	\$0.00	\$11.24	\$1.00	\$0.00	\$0.00	\$68.44	\$91.86

(*)Special Calculation Note :

Other: Health Reimbursement Account

Ratio :

(1) Journeyman Lineman to (1) Apprentice

Jurisdiction (* denotes special jurisdictional note) :

Adams, Ashland, Ashtabula, Athens, Auglaize, Belmont, Brown, Butler, Carroll, Champaign, Clark, Clermont, Clinton, Columbiana, Coshocton, Crawford, Cuyahoga, Darke, Delaware, Fairfield, Fayette, Franklin, Gallia, Geauga, Greene, Guernsey, Hamilton, Harrison, Highland, Hocking, Holmes, Jackson, Jefferson, Knox, Lake, Lawrence, Licking, Logan, Lorain, Madison, Mahoning, Marion, Medina, Meigs, Mercer, Miami, Monroe, Montgomery, Morgan, Morrow, Muskingum, Noble, Perry, Pickaway, Pike, Portage, Preble, Richland, Ross, Scioto, Shelby, Stark, Summit, Trumbull, Tuscarawas, Union, Vinton, Warren, Washington, Wayne

Special Jurisdictional Note :

Details :

Operator "A": John Henry Rock Drill, D-6 (or equivalent) and above, Trackhoe Digger, (320 Track excavator), Cranes (greater than 25 tons and less than 45 tons).
 Operator "B": Cranes (greater than 6 tons and up to 25 tons), Backhoes, Road Tractor, Dozer up to D-5, Pressure Digger- wheeled or tracked, all Tension wire Stringing equipment.
 Operator "C": Trench, Backhoe, Riding type vibratory Compactor, Ground Rod Driver, Boom Truck (6 ton & below), Skid Steer Loaders, Material Handler.

Prevailing Wage Rate Skilled Crafts

Name of Union: Ironworker Local 17

Type of Rate: Commercial

Change #:
LCN01-2020fb

Craft:
Ironworker

Effective Date:
12/24/2020

Effective Date:
12/24/2020

	BHR		Fringe Benefit Payments					Irrevocable Fund		Total PWR	Overtime Rate	
			H&W	Pension	App Tr.	Vac.	Annuity	Other	LECET (*)			MISC (*)
Classification												
Ironworker	\$33.83		\$7.94	\$10.00	\$0.67	\$2.10	\$4.50	\$0.00	\$0.00	\$0.00	\$59.04	\$75.96
Apprentice	BHR	Percent										
1st 6 Months	\$16.92	\$50.00	\$7.94	\$10.00	\$0.67	\$2.10	\$4.50	\$0.00	\$0.00	\$0.00	\$42.13	\$50.58
2nd 6 Months	\$18.61	\$55.00	\$7.94	\$10.00	\$0.67	\$2.10	\$4.50	\$0.00	\$0.00	\$0.00	\$43.82	\$53.12
2nd Year 1st 6 Months	\$23.68	\$70.00	\$7.94	\$10.00	\$0.67	\$2.10	\$4.50	\$0.00	\$0.00	\$0.00	\$48.89	\$60.73
2nd Year 2nd 6 Months	\$25.37	\$75.00	\$7.94	\$10.00	\$0.67	\$2.10	\$4.50	\$0.00	\$0.00	\$0.00	\$50.58	\$63.27
3rd Year 1st 6 Months	\$27.06	\$80.00	\$7.94	\$10.00	\$0.67	\$2.10	\$4.50	\$0.00	\$0.00	\$0.00	\$52.27	\$65.81
3rd Year 2nd 6 Months	\$28.76	\$85.00	\$7.94	\$10.00	\$0.67	\$2.10	\$4.50	\$0.00	\$0.00	\$0.00	\$53.97	\$68.34
4th Year 1st 6 Months	\$30.45	\$90.00	\$7.94	\$10.00	\$0.67	\$2.10	\$4.50	\$0.00	\$0.00	\$0.00	\$55.66	\$70.88
4th Year 2nd 6 Months	\$32.14	\$95.00	\$7.94	\$10.00	\$0.67	\$2.10	\$4.50	\$0.00	\$0.00	\$0.00	\$57.35	\$73.42

(*)Special Calculation Note :

No special calculations for this skilled craft wage rate are required at this time.

Ratio :

4 Journeymen to 1 Apprentice on Structural Work 3 Journeymen to 1 Apprentice on Rod Work 2 Journeymen to 1 Apprentice on Finishing, Steel Sash, Stairway and Ornamental Work 1 Apprentice for every Sheeting Gang 1 Journeymen to 2 Apprentice Roadway Signage and Sound Barriers 2 Journeymen to 2 Apprentice Unloading and Erection of Light Gauge Metal Trusses

Jurisdiction (* denotes special jurisdictional note) :

Ashtabula, Cuyahoga, Erie, Geauga, Huron, Lake, Lorain, Medina, Portage, Summit

Special Jurisdictional Note :

West Boundary Line :Sandusky, Ohio: Boundary lines between Local 17 & Local 55 are as follows: Columbus Ave north to Sandusky Bay (and/or Lake Erie): Columbus Ave South to present Route 4: Route 4 South to present Route 99: from Route 99 south to old Route 224-all territory to the west of the boundary line to be the jurisdiction of Local 55.All territory to the East of the boundary line to be the jurisdiction of Local 17.Kelly's Island to be within jurisdiction of Local 17.All bridges,tunnels,viaducts,etc, relative to these boundary lines shall be the jurisdiction of Local 17 South Boundary Line:Canton, Ohio: Boundary lines between Local 17 & Local 550 are as follows: All territory north of old Route 224 line to be the jurisdiction of Local 17. All bridges,tunnels,viaducts,signs,etc, relative to old Route 224 line to be within the jurisdiction of Local 17. All territory south of old Route 224 line is to be within the jurisdiction of Local 550, except for everything within the city limits of Barberton which shall be the jurisdiction of Local 17. Reading from West to East: Route old 224 line: Greenwich Ave-Wooster Road or East Ave. Route old 224 line: New 224 line including Cloverleaf: East Waterloo Road: New 224 line-Attwood Road-Old 224. This will be considered to be the old Route 224 line,except for the city limits of Barberton, Ohio which shall be the jurisdiction of Local 17 Southeast Boundary : Between local 17 and Local 207 are as follows: West of a line from Middlefield to Shalersville to Deerfield, shall be under the jurisdiction of local 17. East of a line from Middlefield, to Shalersville to Deerfield, shall be under the jurisdiction of Local 207. Local 17 & Local 207 have agreed that the Ohio County of Ashtabula shall be as follows: Everything North of Route 6, starting at the Geauga County line, proceeding east to State Route 45, shall be under the jurisdiction of Local 17. Everything South, starting at the Geauga County line shall be under local 207. North Boundary: The East boundary line and the West boundary line continuing North halfway across Lake Erie.

Details :

Prevailing Wage Rate Skilled Crafts

Name of Union: Labor HevHwy 1B

Type of Rate: Commercial

Change #:
LCN02-2025ib

Craft:
Laborer

Effective Date:
6/11/2025

Effective Date:
6/11/2025

Classification	BHR		Fringe Benefit Payments					Irrevocable Fund		Total PWR	Overtime Rate	
			H&W	Pension	App Tr.	Vac.	Annuity	Other	LECET (*)			MISC (*)
Laborer Group 1	\$38.93		\$8.60	\$4.45	\$0.45	\$0.00	\$2.50	\$0.00	\$0.10	\$0.00	\$55.03	\$74.50
Group 2	\$39.10		\$8.60	\$4.45	\$0.45	\$0.00	\$2.50	\$0.00	\$0.10	\$0.00	\$55.20	\$74.75
Group 3	\$39.43		\$8.60	\$4.45	\$0.45	\$0.00	\$2.50	\$0.00	\$0.10	\$0.00	\$55.53	\$75.25
Group 4	\$39.88		\$8.60	\$4.45	\$0.45	\$0.00	\$2.50	\$0.00	\$0.10	\$0.00	\$55.98	\$75.92
Watch Person	\$32.00		\$8.60	\$4.45	\$0.45	\$0.00	\$2.50	\$0.00	\$0.10	\$0.00	\$48.10	\$64.10
Apprentice	BHR	Percent										
0-1000 hrs	\$31.14	\$80.00	\$8.60	\$4.45	\$0.45	\$0.00	\$2.50	\$0.00	\$0.10	\$0.00	\$47.24	\$62.82
1001-2000 hrs	\$33.09	\$85.00	\$8.60	\$4.45	\$0.45	\$0.00	\$2.50	\$0.00	\$0.10	\$0.00	\$49.19	\$65.74
2001-3000 hrs	\$35.04	\$90.00	\$8.60	\$4.45	\$0.45	\$0.00	\$2.50	\$0.00	\$0.10	\$0.00	\$51.14	\$68.66
3001-4000 hrs	\$36.98	\$95.00	\$8.60	\$4.45	\$0.45	\$0.00	\$2.50	\$0.00	\$0.10	\$0.00	\$53.08	\$71.58
More than 4000 hrs	\$38.93	\$100.00	\$8.60	\$4.45	\$0.45	\$0.00	\$2.50	\$0.00	\$0.10	\$0.00	\$55.03	\$74.50

(*)Special Calculation Note :

Watchman have no Apprentices. Tunnel Laborer rate with air-pressurized add \$1.00 to the above wage rate
Commercial Driver's License – Any Laborer required to utilize a valid Commercial Driver's License (CDL), are in compliance with necessary FMCSA regulations and approved by the Contractor to operate a Commercial Motor Vehicle (CMV), shall be paid one dollar (\$1.00) per hour above the base rate for the entirety of their working shift.

Ratio :

1 Journeymen to 1 Apprentice 3 Journeymen to 1 Apprentice thereafter

Jurisdiction (* denotes special jurisdictional note) :

Cuyahoga, Geauga

Special Jurisdictional Note :

Hod Carriers and Common Laborers - Heavy, Highway, Sewer, Waterworks, Utility, Airport, Railroad, Industrial and Building Site

Details :

Group 1 Laborer (Construction); Plant Laborer or Yardman, Right-of-way Laborer, Landscape Laborer, Highway Lighting Worker, Signalization Worker, (Swimming) Pool Construction Laborer, Utility Man, *Bridge Man, Handyman, Joint Setter, Flagperson, Carpenter Helper, Waterproofing Laborer, Slurry Seal, Seal Coating, Surface Treatment or Road Mix Laborer, Riprap Laborer & Grouter, Asphalt Laborer, Dump Man (batch trucks), Guardrail & Fence Installer, Mesh Handler & Placer, Concrete Curing Applicator, Scaffold Erector, Sign Installer, Hazardous Waste (level D), Diver Helper, Zone Person and Traffic Control. *Bridge Man will perform work as per the October 31, 1949, memorandum on concrete forms, by and between the United Brotherhood of Carpenters and Joiners of America and the Laborers' International Union of North America, which states in; "the moving, cleaning, oiling and carrying to the next point of erection, and the stripping of forms which are not to be re-used, and forms on all flat arch work shall be done by members of the Laborers' International Union of North America." Group 2 Asphalt Raker, Screwman or Paver, Concrete Puddler, Kettle Man (pipeline), All Machine-Driven Tools (Gas, Electric, Air), Mason Tender, Brick Paver, Mortar Mixer, Skid Steer, Sheeting & Shoring Person, Surface Grinder Person, Screedperson, Water Blast, Hand Held Wand, Power Buggy or Power Wheelbarrow, Paint Striper, Plastic fusing Machine Operator, Rodding Machine Operator, Pug Mill Operator, Operator of All Vacuum Devices Wet or Dry, Handling of all Pumps 4 inches and under (gas, air or electric), Diver, Form Setter, Bottom Person, Welder Helper (pipeline), Concrete Saw Person, Cutting with Burning Torch, Pipe Layer, Hand Spiker (railroad), Underground Person (working in sewer and waterline, cleaning, repairing and reconditioning). Tunnel Laborer (without air), Caisson, Cofferdam (below 25 feet deep), Air Track and Wagon Drill, Sandblaster Nozzle Person, Hazardous Waste (level B), ***Lead Abatement, Hazardous Waste (level C) ***Includes the erecting of structures for the removal, including the encapsulation and containment of Lead abatement process. Group 3 Blast and Powder Person, Muckers will be defined as shovel men working directly with the miners, Wrencher (mechanical joints & utility pipeline), Yarnier, Top Lander, Hazardous Waste (level A), Concrete Specialist, Curb Setter and Cutter, Grade Checker, Concrete Crew in Tunnels. Utility pipeline Tappers, Waterline, Caulker, Signal Person will receive the rate equal to the rate paid the Laborer classification for which the Laborer is signaling. Group 4 Miner, Welder, Guniting Nozzle Person A.) The Watchperson shall be responsible to patrol and maintain a safe traffic zone including but not limited to barrels, cones, signs, arrow boards, message boards etc. The responsibility of a watchperson is to see that the equipment, job and office trailer etc. are secure.

Prevailing Wage Rate Skilled Crafts

Name of Union: Operating Engineers - HevHwy Zone I

Type of Rate: Commercial

Change #:
LCN01-2025ib

Craft:
Operating Engineer

Effective Date:
5/1/2025

Effective Date:
5/1/2025

	BHR		Fringe Benefit Payments					Irrevocable Fund		Total PWR	Overtime Rate	
			H&W	Pension	App Tr.	Vac.	Annuity	Other	LECET (*)			MISC (*)
Classification												
Operator Class A	\$47.33		\$9.51	\$6.25	\$0.95	\$0.00	\$0.00	\$0.09	\$0.00	\$0.10	\$64.23	\$87.90
Operator Class B	\$47.23		\$9.51	\$6.25	\$0.95	\$0.00	\$0.00	\$0.09	\$0.00	\$0.10	\$64.13	\$87.75
Operator Class C	\$46.19		\$9.51	\$6.25	\$0.95	\$0.00	\$0.00	\$0.09	\$0.00	\$0.10	\$63.09	\$86.19
Operator Class D	\$44.97		\$9.51	\$6.25	\$0.95	\$0.00	\$0.00	\$0.09	\$0.00	\$0.10	\$61.87	\$84.36
Operator Class E	\$39.68		\$9.51	\$6.25	\$0.95	\$0.00	\$0.00	\$0.09	\$0.00	\$0.10	\$56.58	\$76.42
Master Mechanic	\$48.33		\$9.51	\$6.25	\$0.95	\$0.00	\$0.00	\$0.09	\$0.00	\$0.10	\$65.23	\$89.40
Lift Director	\$48.33		\$9.51	\$6.25	\$0.95	\$0.00	\$0.00	\$0.09	\$0.00	\$0.10	\$65.23	\$89.40
Crane and Mobile Concrete Pump 150' - 179'	\$47.83		\$9.51	\$6.25	\$0.95	\$0.00	\$0.00	\$0.09	\$0.00	\$0.10	\$64.73	\$88.65
Crane and Mobile Concrete Pump 180' - 249'	\$48.33		\$9.51	\$6.25	\$0.95	\$0.00	\$0.00	\$0.09	\$0.00	\$0.10	\$65.23	\$89.40
Crane and Mobile Concrete Pump 250' and Over	\$48.58		\$9.51	\$6.25	\$0.95	\$0.00	\$0.00	\$0.09	\$0.00	\$0.10	\$65.48	\$89.77
Apprentice	BHR	Percent										
1st Year	\$23.67	\$50.00	\$9.51	\$6.25	\$0.95	\$0.00	\$0.00	\$0.09	\$0.00	\$0.10	\$40.57	\$52.40
2nd Year	\$28.40	\$60.00	\$9.51	\$6.25	\$0.95	\$0.00	\$0.00	\$0.09	\$0.00	\$0.10	\$45.30	\$59.50
3rd Year	\$33.13	\$70.00	\$9.51	\$6.25	\$0.95	\$0.00	\$0.00	\$0.09	\$0.00	\$0.10	\$50.03	\$66.60
4th Year	\$37.86	\$80.00	\$9.51	\$6.25	\$0.95	\$0.00	\$0.00	\$0.09	\$0.00	\$0.10	\$54.76	\$73.70
Field Mech Trainee	\$	\$	\$	\$	\$	\$	\$	\$	\$	\$	\$	\$
1st year	\$28.40	\$60.00	\$9.51	\$6.25	\$0.95	\$0.00	\$0.00	\$0.09	\$0.00	\$0.00	\$45.30	\$59.50
2nd year	\$33.13	\$70.00	\$9.51	\$6.25	\$0.95	\$0.00	\$0.00	\$0.09	\$0.00	\$0.00	\$50.03	\$66.60
3rd year	\$37.86	\$80.00	\$9.51	\$6.25	\$0.95	\$0.00	\$0.00	\$0.09	\$0.00	\$0.00	\$54.76	\$73.70
4th year	\$42.60	\$90.00	\$9.51	\$6.25	\$0.95	\$0.00	\$0.00	\$0.09	\$0.00	\$0.00	\$59.50	\$80.80

(*)Special Calculation Note :

Other: Education & Safety Fund Misc: National Training

Ratio :

For every (3) Operating Engineer Journeymen employed by the company, there may be employed (1) Registered Apprentice or Trainee Engineer through the referral when they are available. An Apprentice, while employed as part of a crew per Article VIII, paragraph 68 will not be subject to the apprenticeship ratios in this collective bargaining agreement

Jurisdiction (* denotes special jurisdictional note) :

Ashtabula, Cuyahoga, Erie, Geauga, Lake, Lorain, Medina, Portage, Summit

Special Jurisdictional Note :

Details :

**Apprentices will receive a 10% increase on top of the percentages listed above provided they are operating mobile equipment.

Class A - Air Compressors on Steel Erection; Asphalt Plant Engineers (Cleveland District Only); Barrier Moving Machine; Boiler Operators, Compressor Operators, or Generators, when mounted on a rig; Boom Trucks (all types); Cableways; Cherry Pickers; Combination- Concrete Mixers & Towers; Concrete Plants (over 4 yd capacity); Concrete Pumps; Cranes (all types); Compact Cranes track or rubber over 4,000 pounds capacity; Cranes self-erecting stationary, track or truck; Derricks (all types); Draglines; Dredges dipper, clam or suction; Elevating Graders or Euclid Loaders; Floating Equipment (all types); Gradalls; Helicopter Crew (Operator- hoist or winch); Hoes (all types); Hoisting Engines; Hoisting Engines, on shaft or tunnel work; Hydraulic Gantry (lifting system); Industrial-type Tractors; Jet Engine Dryer (D8 or D9) diesel Tractors; Locomotives (standard gauge); Maintenance Operators/Technicians (class A); Mixers, paving (single or double drum); Mucking Machines; Multiple Scrapers; Piledriving Machines (all types); Power Shovels, Prentice Loader; Quad 9 (double pusher); Rail Tamper (with automatic lifting and aligning device); Refrigerating Machines (freezer operation); Rotary Drills, on caisson work; Rough Terrain Fork Lift with winch/hoist; Side Booms; Slip Form Pavers; Survey Crew Party Chiefs; Tower Derricks; Tree Shredders; Trench Machines (over 24" wide); Truck Mounted Concrete Pumps; Tug Boats; Tunnel Machines and /or Mining Machines; Wheel Excavators.

Class B - Asphalt Pavers; Automatic Subgrade Machines, self-propelled (CMI-type); Bobcat-type and /or Skid Steer Loader with hoe attachment greater than 7000 lbs.; Boring Machine Operators (more than 48 inches); Bulldozers; Concrete Saws, Vermeer type; Endloaders; Horizontal Directional Drill (50,000 ft. lbs. thrust and over); Hydro Milling Machine; Kolman-type Loaders (production type-dirt); Lead Greasemen; Lighting and Traffic Signal Installation Equipment includes all groups or classifications; Maintenance Operators/Technicians, Class B - Material Transfer Equipment (shuttle buggy) Asphalt; Pettibone-Rail Equipment; Power Graders; Power Scrapers; Push Cats; Rotomills (all), Grinders and Planners of all types, Groovers (excluding walk-behinds); Trench Machines (24 inch wide and under).

Class C - A-Frames; Air Compressors, on tunnel work (low Pressure); Articulating/straight bed end dumps if assigned (minus \$4.00 per hour); Asphalt Plant Engineers (Portage and Summit Counties only); Bobcat-type and/or skid steer loader with or without attachments; Drones; Highway Drills (all types); HydroVac/Excavator (when a second person is needed, the rate of pay will be "Class E"); Locomotives (narrow gauge); Material Hoist/Elevators; Mixers, concrete (more than one bag capacity); Mixers, one bag capacity (side loader); Power Boilers (over 15 lbs. pressure); Pump Operators (installing or operating well Points); Pumps (4 inch and over discharge); Railroad Tie Inserter/Remover; Rollers, Asphalt; Rotovator (lime-soil Stabilizer); Switch & Tie Tampers (without lifting and aligning device); Utilities Operators, (small equipment); Welding Machines and Generators.

Class D – Backfillers and Tampers; Ballast Re-locator; Bar and Joint Installing Machines; Batch Plant Operators; Boring Machine Operators (48 inch or less); Bull Floats; Burlap and Curing Machines; Concrete Plants (capacity 4 yds. and under); Concrete Saws (multiple); Conveyors (highway); Crushers; Deckhands; Farm type tractors, with attachments (highway); Finishing Machines; Firemen, Floating Equipment (all types); Fork Lifts (highway), except masonry; Form Trenchers; Hydro Hammers; Hydro Seeders; Pavement Breakers (hydraulic or cable); Plant Mixers; Post Drivers; Post Hole Diggers; Power Brush Burners; Power Form Handling Equipment; Road Widening Trenchers; Rollers (brick, grade, macadam); Self-Propelled Power Spreaders; Self-Propelled Sub-Graders; Steam Firemen; Survey Instrument men; Tractors, pulling sheepsfoot rollers or graders; Vibratory Compactors, with integral power.

Class E - Compressors (portable, Sewer, Heavy and Highway); Cranes-Compact, track or rubber under 4,000 pound capacity; Drum Firemen (asphalt plant); Fueling and greasing (Primary Operator with Specialized CDL Endorsement Add \$3.00/hr); Generators; Inboard-Outboard Motor Boat Launches; Masonry Fork Lifts; Oil Heaters (asphalt plant); Oilers/Helpers; Power Driven Heaters (oil fired); Power Scrubbers; Power Sweepers; Pumps (under 4 inch discharge); Signalperson; Survey Rodmen or Chairmen; Tire Repairmen; VAC/ALLS.

Master Mechanic - Master Mechanic

Cranes and Mobile Concrete Pumps 150' -179' - Boom & Jib 150 - 179 feet
Cranes and Mobile Concrete Pumps 180' - 249' - Boom & Jib 180 - 249 feet
Cranes and Mobile Concrete Pumps 250' and over - Boom & Jib 250 feet or over

Prevailing Wage Rate Skilled Crafts

Name of Union: Painter Local 707 HvyHwy

Type of Rate: Commercial

Change #:
LCN01-2025ib

Craft:
Painter

Effective Date:
7/16/2025

Effective Date:
7/16/2025

Classification	BHR	Fringe Benefit Payments						Irrevocable Fund		Total PWR	Overtime Rate
		H&W	Pension	App Tr.	Vac.	Annuity	Other	LECET (*)	MISC (*)		
Class 1: Bridge Blaster	\$41.71	\$9.52	\$6.08	\$0.45	\$0.00	\$4.15	\$0.00	\$0.00	\$0.00	\$61.91	\$82.77
Class 2: Bridge Painter, Rigger, Containment Builder, Spot Blaster	\$38.91	\$9.52	\$6.08	\$0.45	\$0.00	\$4.15	\$0.00	\$0.00	\$0.00	\$59.11	\$78.56
Class 3: Equipment Operator/ Field Mechanic, Grit Reclamation, Paint Mixer, Traffic Control Boat Person, Driver (0-5 Years Exp.)	\$31.71	\$9.52	\$6.08	\$0.45	\$0.00	\$4.15	\$0.00	\$0.00	\$0.00	\$51.91	\$67.77
Class 3: Equipment Operator/ Field Mechanic, Grit Reclamation, Paint Mixer, Traffic Control Boat Person, Driver (5 Plus Years Exp.)	\$34.71	\$9.52	\$6.08	\$0.45	\$0.00	\$4.15	\$0.00	\$0.00	\$0.00	\$54.91	\$72.27
Class 4: Concrete Sealing, Concrete Blasting/P ower Washing/ Etc	\$30.71	\$9.52	\$6.08	\$0.45	\$0.00	\$4.15	\$0.00	\$0.00	\$0.00	\$50.91	\$66.27

Class 5: Quality Control/Q uality Assurance , Traffic Safety, Competen t Person	\$34.71		\$9.52	\$6.08	\$0.45	\$0.00	\$4.15	\$0.00	\$0.00	\$0.00	\$54.91	\$72.27
Apprentice	BHR	Percent										
1st Year	\$27.11	\$65.00	\$9.52	\$1.64	\$0.45	\$0.00	\$0.00	\$0.00	\$0.00	\$0.00	\$38.72	\$52.27
2nd Year	\$31.28	\$75.00	\$9.52	\$2.25	\$0.45	\$0.00	\$2.91	\$0.00	\$0.00	\$0.00	\$46.41	\$62.05
3rd Year	\$35.45	\$85.00	\$9.52	\$2.70	\$0.45	\$0.00	\$3.32	\$0.00	\$0.00	\$0.00	\$51.44	\$69.17

(*)Special Calculation Note :

Apprentice pay based on percentage of above appropriate classification.

Application of Catalytic materials under class 3 hazardous per MSDS- add .65 per hour to the above Job Classification basic hourly rate.

Application of Catalytic materials under class 4 hazardous per MSDS- add 1.00 per hour to the above Job Classification basic hourly rate.

Ratio :

1 Apprentice to 1 Journeyman

Jurisdiction (* denotes special jurisdictional note) :

Ashtabula, Cuyahoga, Geauga, Lake, Lorain, Portage*, Summit*

Special Jurisdictional Note :

Portage & Summit North of the East-West Turnpike.

Details :

Painter Bridge Class 2 is Defined as; Bridge Painter, Rigger, Containment Builder

Concrete Sealing: on highway work, scaling of concrete surfaces, the treating and sealing of bridge decks, the painting and staining of concrete, including the abutments, barricades, noise barriers, lane dividers, etc.

Prevailing Wage Rate Skilled Crafts

Name of Union: Pipefitter Local 120

Type of Rate: Commercial

Change #:
LCN01-2025ib

Craft:
Pipefitter

Effective Date:
6/11/2025

Effective Date:
6/11/2025

	BHR		Fringe Benefit Payments					Irrevocable Fund		Total PWR	Overtime Rate	
			H&W	Pension	App Tr.	Vac.	Annuity	Other	LECET (*)			MISC (*)
Classification												
Pipefitter	\$49.17		\$13.05	\$11.80	\$1.27	\$0.00	\$3.50	\$0.20	\$0.00	\$0.00	\$78.99	\$103.58
Apprentice	BHR	Percent										
1st year	\$23.83	\$48.46	\$5.70	\$0.00	\$1.27	\$0.00	\$0.00	\$0.00	\$0.00	\$0.00	\$30.80	\$42.71
2nd year	\$24.57	\$49.97	\$12.23	\$7.20	\$1.27	\$0.00	\$0.88	\$0.20	\$0.00	\$0.00	\$46.35	\$58.64
3rd year	\$28.45	\$57.86	\$12.23	\$7.20	\$1.27	\$0.00	\$0.88	\$0.20	\$0.00	\$0.00	\$50.23	\$64.45
4th year	\$33.89	\$68.92	\$12.23	\$7.20	\$1.27	\$0.00	\$0.88	\$0.20	\$0.00	\$0.00	\$55.67	\$72.61
5th year	\$37.78	\$76.84	\$12.23	\$7.20	\$1.27	\$0.00	\$0.88	\$0.20	\$0.00	\$0.00	\$59.56	\$78.45

(*)Special Calculation Note :

OTHER: SUPPLEMENTAL UNEMPLOYMENT BENEFITS

Ratio :

1 Journeyman to 1 Apprentice 2-4 Journeymen to 2 Apprentices 5-7 Journeymen to 3 Apprentices 3 to 1 on jobs with 12 or more journeymen

Jurisdiction (* denotes special jurisdictional note) :

Ashtabula, Cuyahoga, Geauga, Lake, Medina*, Summit*

Special Jurisdictional Note :

Summit County - North of State Route 303 including work within the corporate limits of the City of Hudson, that portion of Medina County North of State Route 18 and Smith Road and including work within the corporate limits of the City of Medina.

Details :

Under pipefitter duties shall include - steam and hot water heating boilers and related controls such as automatic feedwater and low water cut-offs, safety relief valves and gas trains; steam regulators, traps, steam valves, steam heaters, steam and hot water heating coils; feedwater lines to boilers, condensate pumps, condensate tanks and related piping to boilers, expansion tanks and controls on hot water heating systems; refrigeration and air conditioning systems that are separate from one another and are connected through piping; install, calibrate and maintain pneumatic temperature controls and piping for heating and cooling devices; piping, pumps and controls on the fluent water system in water treatment plants; hose cabinets and automatic fire sprinkler systems; underground water supply piping and devices; all fire stopping of piping systems; to operate a pipe cutting machine, to thread pipe by machine or hand dies; to do oxyacetylene and electric welding on iron and steel pipes when required; to perform other tasks when assigned.

Prevailing Wage Rate Skilled Crafts

Name of Union: Plumber Local 55

Type of Rate: Commercial

Change #:
LCN01-2025ib

Craft:
Plumber

Effective Date:
5/21/2025

Effective Date:
5/21/2025

Classification	BHR		Fringe Benefit Payments					Irrevocable Fund		Total PWR	Overtime Rate	
			H&W	Pension	App Tr.	Vac.	Annuity	Other	LECET (*)			MISC (*)
Plumber	\$44.86		\$12.87	\$9.63	\$1.23	\$0.00	\$7.10	\$0.20	\$0.00	\$0.00	\$75.89	\$98.32
Shopman (When in the field)	\$24.69		\$9.50	\$5.59	\$0.10	\$0.00	\$3.85	\$0.00	\$0.00	\$0.00	\$43.73	\$56.08
Plumber Light Commercial Journeymen	\$29.42		\$9.18	\$2.28	\$0.69	\$0.00	\$3.58	\$0.20	\$0.00	\$0.00	\$45.35	\$60.06
Apprentice Light Commercial Trainee	\$		\$	\$	\$	\$	\$	\$	\$	\$	\$	\$
0-3 Months	\$14.84		\$0.00	\$0.00	\$0.50	\$0.00	\$0.00	\$0.00	\$0.00	\$0.00	\$15.34	\$22.76
4-6 Months	\$15.03		\$3.69	\$0.00	\$0.46	\$0.00	\$0.00	\$0.00	\$0.00	\$0.00	\$19.18	\$26.70
7-12 Months	\$15.32		\$4.42	\$0.33	\$0.63	\$0.00	\$1.13	\$0.00	\$0.00	\$0.00	\$21.83	\$29.49
2nd Year	\$16.67		\$4.49	\$0.35	\$0.65	\$0.00	\$1.20	\$0.00	\$0.00	\$0.00	\$23.36	\$31.70
3rd Year	\$18.03		\$4.55	\$0.36	\$0.68	\$0.00	\$1.28	\$0.00	\$0.00	\$0.00	\$24.90	\$33.92
Apprentice	BHR	Percent										
1-6 Months	\$19.80	\$44.14	\$7.39	\$0.24	\$0.95	\$0.00	\$1.56	\$0.00	\$0.00	\$0.00	\$29.94	\$39.84
7-12 Months	\$22.50	\$50.15	\$7.61	\$0.44	\$1.00	\$0.00	\$2.01	\$0.20	\$0.00	\$0.00	\$33.76	\$45.01
2nd year 1-6	\$24.07	\$53.65	\$8.37	\$0.85	\$1.05	\$0.00	\$3.06	\$0.20	\$0.00	\$0.00	\$37.60	\$49.63
2nd year 7-12	\$25.01	\$55.76	\$8.55	\$2.85	\$1.05	\$0.00	\$3.78	\$0.20	\$0.00	\$0.00	\$41.44	\$53.95
3rd year 1-6	\$28.09	\$62.61	\$9.08	\$2.80	\$1.05	\$0.00	\$4.00	\$0.20	\$0.00	\$0.00	\$45.22	\$59.26
3rd year 7-12	\$30.24	\$67.40	\$9.32	\$3.63	\$1.05	\$0.00	\$4.62	\$0.20	\$0.00	\$0.00	\$49.06	\$64.17
4th year	\$33.02	\$73.60	\$9.57	\$4.07	\$1.05	\$0.00	\$4.98	\$0.20	\$0.00	\$0.00	\$52.89	\$69.40
5th year	\$35.83	\$79.88	\$9.81	\$4.51	\$1.05	\$0.00	\$5.33	\$0.20	\$0.00	\$0.00	\$56.73	\$74.65

(*)Special Calculation Note :

OTHER IS: SUPPLEMENTAL UNEMPLOYMENT

Ratio :

1 Journeyman 1 Apprentice 2 Journeymen to 1 Apprentice thereafter Light Commercial Ratio 1-2 Journeymen to 1 Trainee 3 Journeymen to 2 Trainees 4-5 Journeymen to 3 Trainees 6-8 Journeymen to 4 Trainees 9-10 Journeymen to 5 Trainees 11-13 Journeymen to 6 Trainees

Jurisdiction (* denotes special jurisdictional note) :

Ashtabula, Cuyahoga, Geauga, Lake, Medina*, Summit*

Special Jurisdictional Note :

Summit County - North of State Route 303 including work within the corporate limits of the City of Hudson, that portion of Medina County North of Route 18 and Smith Road and the corporate limits of the City of Medina.

Details :

The Plumber Shopman will have charge of the Employer's shop and warehouse containing plumbing and heating supplies and equipment, and perform such duties as are customarily required by a Plumber or a Plumber's Shopman, including casual delivery of tools and equipment necessary for installation of Plumbing and Heating facilities. One field shopman per shop may be hired after employing the 1st apprentice, and a second field shopman per shop may be hired after employing the 5th apprentice. These shopmen may work in the field performing primarily non-mechanical work. The plumber shopman's duties do not include the installation of plumbing. The Plumber Light Commercial Rate can be used for the following: Any private construction project covered by this agreement shall be eligible for designation as a Market Recovery Project (Lt Commercial). The Market Recovery (Lt Commercial) wage rate shall be determined project specific by the business manager. The Market Recovery rate (Lt Commercial) may be utilized on all new, repair, remodeling, alteration, and/or maintenance (interior and exterior) of "Private Enterprise Projects"; including office buildings, service buildings, retail establishments, churches, motels/hotels, and strip shopping centers which fall under this agreement.

Prevailing Wage Rate Skilled Crafts

Name of Union: Truck Driver Local 436 - HevHwy Class 1

Type of Rate: Commercial

Change #:
LCN02-2025ib

Craft:
Truck Driver

Effective Date:
5/28/2025

Effective Date:
5/28/2025

	BHR		Fringe Benefit Payments					Irrevocable Fund		Total PWR	Overtime Rate	
			H&W	Pension	App Tr.	Vac.	Annuity	Other	LECET (*)			MISC (*)
Classification												
Truck Driver CLASS 1	\$34.92		\$9.25	\$10.05	\$0.40	\$0.00	\$0.00	\$0.00	\$0.00	\$0.00	\$54.62	\$72.08
Apprentice	BHR	Percent										
First 6 months	\$27.94	\$80.00	\$9.25	\$10.05	\$0.40	\$0.00	\$0.00	\$0.00	\$0.00	\$0.00	\$47.64	\$61.60
7-12 months	\$29.68	\$85.00	\$9.25	\$10.05	\$0.40	\$0.00	\$0.00	\$0.00	\$0.00	\$0.00	\$49.38	\$64.22
13-18 months	\$31.43	\$90.00	\$9.25	\$10.05	\$0.40	\$0.00	\$0.00	\$0.00	\$0.00	\$0.00	\$51.13	\$66.84
19-24 months	\$33.17	\$95.00	\$9.25	\$10.05	\$0.40	\$0.00	\$0.00	\$0.00	\$0.00	\$0.00	\$52.87	\$69.46
25-30 months	\$34.92	\$100.00	\$9.25	\$10.05	\$0.40	\$0.00	\$0.00	\$0.00	\$0.00	\$0.00	\$54.62	\$72.08

(*)Special Calculation Note :

Ratio :

3 Journeymen to 1 Apprentice

Jurisdiction (* denotes special jurisdictional note) :

Cuyahoga, Geauga, Lake

Special Jurisdictional Note :

Details :

CLASS 1: Drivers on trucks, including but not limited to: 4-wheel service trucks; 4-wheel dump trucks; batch trucks; drivers on tandems; truck sweepers (not to include power sweepers and scrubbers) Drivers on tractor – trailer combinations including but not limited to the following: Semi-tractor trucks; pole trailers; ready-mix trucks; fuel trucks; all trucks five (5) axle and over; drivers on belly dumps; truck mechanics (when needed).

Prevailing Wage Rate Skilled Crafts

Name of Union: Truck Driver Local 436 - HevHwy Class 2

Type of Rate: Commercial

Change #:
LCN02-2025ib

Craft:
Truck Driver

Effective Date:
5/28/2025

Effective Date:
5/28/2025

	BHR		Fringe Benefit Payments						Irrevocable Fund		Total PWR	Overtime Rate
			H&W	Pension	App Tr.	Vac.	Annuity	Other	LECET (*)	MISC (*)		
Classification												
Truck Driver CLASS 2	\$35.73		\$9.25	\$10.05	\$0.40	\$0.00	\$0.00	\$0.00	\$0.00	\$0.00	\$55.43	\$73.30
Apprentice	BHR	Percent										
First 6 months	\$28.58	\$80.00	\$9.25	\$10.05	\$0.40	\$0.00	\$0.00	\$0.00	\$0.00	\$0.00	\$48.28	\$62.58
7-12 months	\$30.37	\$85.00	\$9.25	\$10.05	\$0.40	\$0.00	\$0.00	\$0.00	\$0.00	\$0.00	\$50.07	\$65.26
13-18 months	\$32.16	\$90.00	\$9.25	\$10.05	\$0.40	\$0.00	\$0.00	\$0.00	\$0.00	\$0.00	\$51.86	\$67.94
19-24 months	\$33.94	\$95.00	\$9.25	\$10.05	\$0.40	\$0.00	\$0.00	\$0.00	\$0.00	\$0.00	\$53.64	\$70.62
25-30 months	\$35.73	\$100.00	\$9.25	\$10.05	\$0.40	\$0.00	\$0.00	\$0.00	\$0.00	\$0.00	\$55.43	\$73.30

(*)Special Calculation Note :

Ratio :

3 Journeymen to 1 Apprentice

Jurisdiction (* denotes special jurisdictional note) :

Cuyahoga, Geauga, Lake

Special Jurisdictional Note :

Details :

CLASS 2: Drivers on articulated dump trucks; rigid-frame rock trucks; distributor trucks; low boys/drag driver on the construction site only and heavy duty equipment (irrespective of load carried) when used exclusively for transportation on the construction site only.